

# Method for *in vitro* assessment of straylight from intraocular lenses

Łabuz G, Vargas-Martín F, van den Berg TJTP, López-Gil N

*Biomed Opt Express*. 2015 Oct 19;6(11):4457-64

## **ABSTRACT**

Ocular straylight has been measured by means of psychophysical methods over the years. This approach gives a functional parameter yielding a straight comparison with optically defined light scattering, and the point spread function. This is of particular importance when the effect of intraocular lenses (IOLs) on postoperative straylight is sought. An optical system for straylight measurements of IOLs was adapted to a commercial device (C-Quant, Oculus), which employs such psychophysical method. The proposed modifications were validated using light-scattering filters and some sample IOLs. The measurements were performed by 3 observers to prove that results are independent from straylight of the eye. Other applications will be discussed.

## INTRODUCTION

Intraocular straylight refers to the effect that light scattered (forward direction) by the ocular media is projected on the retina and decreases contrast of the in-focus image. According to the CIE (Commission Internationale d'Éclairage) disability glare must be quantified by means of straylight, as (the outer) part of the Point Spread Function (PSF).<sup>1</sup> The PSF is defined as the fraction of light scattered per steradian. This is a 2-dimensional function, but the PSF is by approximation radially symmetric, certainly for larger radial angle  $\theta$  in most eyes. For that reason the CIE standard is given as function of radial angle only, as  $\text{PSF}(\theta)$ .<sup>2</sup> The straylight parameter is defined as:

$$s = \theta^2 \times \text{PSF}(\theta) \text{ [deg}^2/\text{sr]}, \quad (1)$$

with  $\theta$  the visual angle in degrees, and is as a rule presented logarithmically as  $\log(s)$ . Straylight of the eye can be assessed by measuring the eye's PSF at the respective angular distance of a light source. By using an annular light source the radial average value of the PSF can be obtained. This approach has been applied in many studies on ocular straylight that involved various techniques,<sup>3</sup> however, recently a commercial apparatus (C-Quant, Oculus) has become a standard used in laboratory and clinical practice.<sup>3</sup> This instrument delivers the straylight parameter based on the psychophysical compensation comparison method and provides repeatable and reliable straylight values.<sup>4, 5</sup>

The C-Quant has also been used to measure straylight from optical materials like light scattering filters<sup>6</sup> or corneal implants<sup>7</sup> without interference from scattering of the eye. This application can be understood as follows. In the C-Quant a flickering ring serves as source of straylight. It induces straylight at the fixation point in the middle of the ring. This flickering straylight is compared to a comparison field. Now suppose that we place in front of the eye a piece of light scattering material, and block at the same time the flickering light from entering the eye. Then the eye will only see the straylight originating from the piece of material and not its own straylight. This method was checked against optically measured values and found to reproduce the optical values precisely.<sup>6</sup>

Straylight values whether assessed inside or outside the eye can be considered by good approximation the same. Straylight from an eye can be addressed as the addition of the straylight from different scattering layers, for instance, a layer placed at the cornea. If one considers scattering sources deeper in the eye (limited to the anterior segment), only the effective angle of the incident light changes. This is however of little consequence if straylight is assessed by means of the straylight parameter, since the straylight parameter is by good approximation invariant with angle.<sup>8, 9</sup> Therefore, the C-Quant can be used to measure straylight originating from other structures, such as an intraocular lens (IOL). Nevertheless, it is important to point out that the assumption of invariant angle is limited to relatively small errors in the angular distance, but this will be discussed later in the manuscript.

In the normal young eye the straylight parameter is at a level of 0.9 log(s).<sup>10</sup> As the eye ages intraocular straylight increases, and at 65 years a 2-fold increase can be expected and a 3-fold increase at the age of 77.<sup>10</sup> But an elevated straylight level is also associated with many ophthalmological conditions such as: corneal dystrophies, vitreous turbidity, cataract, posterior capsule opacification and IOL opacity.<sup>3</sup> These pathologies lead to decreased visual quality and functional difficulties like hazy vision, disability glare, halos around light sources and loss of color vision.<sup>11, 12</sup>

In most cases cataract removal and IOL implantation succeeds in lowering intraocular straylight, albeit that up to 15% of cataract patients experience increase or no-improvement in straylight after the surgery.<sup>13</sup> It is speculated that the observed increase might be related to implanted IOLs depending on their materials, optical designs and manufacturing processes.

Straylight of IOLs has been studied solely on an optical bench set-up.<sup>14, 15</sup> The use of the C-Quant in straylight evaluation of IOLs can make these measurements more accessible for researchers. This method gives a straylight value that can directly be compared with the clinical measurements. This can e.g. be used when the effect of explanted IOLs on ocular straylight is sought.<sup>16, 17</sup>

The purpose of this study was to develop a method to measure straylight of IOLs objectively using the C-Quant and deliver the functional straylight parameter that can be applied in clinical practice.

## METHODS

### Psychophysical measurements

The C-Quant straylight meter evaluates ocular straylight by means of the psychophysical compensation comparison method. The basics of this methodology have been thoroughly studied.<sup>18, 19</sup> In short, an annular straylight source (from 5° to 10° radius) is presented flickering at different intensities in black and white. A central test field with diameter of 3.3° is presented, subdivided in 2 halves one of which flickers in counter-phase with different modulation depths. No flicker is presented in the other half, and as consequence only light scattered from the straylight source is seen in that half. The opposite part comprises scattered light, and additionally, the counter-phase compensation light. The patient fixates the central field and indicates which of the observed halves flickers stronger using two buttons. The ratio between the intensities of the compensation light and the annulus is varied during evaluation. At a certain moment, both halves appear to be equal and the subject must guess which one flickers stronger. Therefore, this approach is called a two alternative forced choice method. It provides a psychometric curve from which the straylight parameter can be determined.

This method can also be used for evaluation of light-scattering objects without interference by the light scattering properties of the eye being used.<sup>6,7</sup> Because normally only a very small fraction of light is scattered in total, different sources of straylight in the eye and of scattering objects are additive in the standard C-Quant measurements. However, if the object is exposed to the straylight source but the observer sees only the central field by blocking the straylight source for his eye, then an independent straylight parameter can be obtained for the object. In this case, the eye only judges the light scattered by the object against the comparison test field without any contribution to the straylight produced by his/her own eye. This can be achieved by positioning the observer at a certain distance from the C-Quant where the flickering annulus is not perceived, or alternatively, by using an additional field-stop.

### Adaptation of the psychophysical system

The C-Quant straylight meter was proven to give the precise value of the straylight parameter by using scattering filters in this manner,<sup>6</sup> but the evaluation of straylight from IOLs requires an adaptation. The main reason for the adaptation is the high refractive power of IOLs as well as the small size of their optical zone, which rarely exceeds 6 mm diameter. In order to estimate the clinical importance of straylight produced by IOLs, the angular relation between the scattering source and the evaluated sample must comply with the condition when straylight of the eye is measured. As it was mentioned before, in order to avoid the influence of straylight of the observer's eye, his/her eye cannot be exposed to the straylight source.

The adaptation was designed using the OpticStudio 15 software (Zemax LLC, Kirkland, WA, USA). The Liou & Brennan eye model<sup>20</sup> was assigned to find at what angle the crystalline lens "sees" the image, produced by  $L_{CQ}$ , of the scattering ring (**Figure 1**).

The performed calculation resulted in an angle of 8.8° for the outer rim of the flickering annulus. The resulting C-Quant system adjusted to the IOL measurements is presented in **Figure 2**.

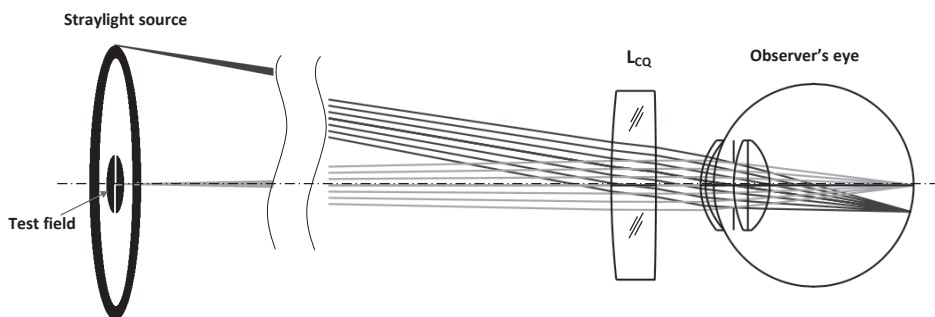

**Figure 1.** Straylight measurement of the eye – schematic illustration (not to scale).  $L_{CQ}$  is a fixed lens in the C-Quant used to view the straylight source and the central field.

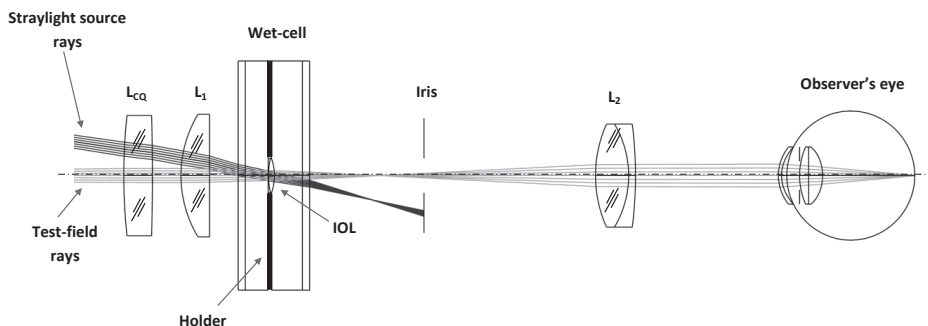

**Figure 2.** The C-Quant adaptation to measure straylight of IOLs (not to scale).  $L_1$  is placed 5 mm behind the C-Quant lens ( $L_{CQ}$ ). The front of the wet-cell and the back of  $L_1$  are at a distance of 5 mm as well. The holder with an IOL is set at 1 mm to the cuvette's innersurface. The iris acts as a field-stop intercepting the rays that come from the flickering annulus while the test field can still be seen with help of the magnifying lens  $L_2$ .

The adaptation of the C-Quant system included a plano-convex lens ( $L_1$ ;  $f'_1 = 40$  mm, Linos-Qioptiq, Göttingen, Germany), and a wet-cell (6030-UV-10-531, Hellma GmbH & Co. KG, Müllheim, Germany) with a sample IOL. These components allow the light from the flickering ring to arrive at the IOL at  $9.3^\circ$ , a value similar to the  $8.8^\circ$  obtained in the human eye model (**Figure 1**). The system also contained an iris acting as a field-stop and an achromatic lens ( $L_2$ ;  $f'_2 = 40$  mm, Linos-Qioptiq, Göttingen, Germany) to generate an image of the test field at the observer's far point. All components were mounted using standard rods and holders as presented in **Figure 3**.



**Figure 3.** Adaptation of the C-Quant to evaluate straylight from IOLs.

A sample was prepared as follows; the IOL was gently mounted in a steel-made holder, then the IOL-holder set was submerged in a saline solution of 0.9% that filled the wet-cell. The IOL holder acts as natural pupil with an aperture of 5.5 mm. The wet-cell was inserted in a rectangular opaque component created using a 3D-printer to block any parasitic light reflected by the walls of the cuvette. The iris constraints the light that comes from the straylight source, but the test field still reaches the observer's eye, and this enables to perform straylight measurements of IOLs.

With this system, the straylight value both with and without the IOL could be obtained. In both cases, the test field can be seen in focus by the observer by moving  $L_2$  inward (with IOL) or outward (without IOL) with respect to  $L_1$ . Neither of the system's components was removed at any stage of the trial, therefore, the same conditions can be maintained through the complete experiment. Straylight of the IOL was calculated as a linear subtraction of 2 straylight parameters using the following formula:

$$\log(S_{\text{IOL}}) = \log(10^{\log(S_{\text{setup+IOL}})} - 10^{\log(S_{\text{setup}})}) \quad (2)$$

The values  $\log(S_{\text{setup+IOL}})$  and  $\log(S_{\text{setup}})$  are provided by the C-Quant and denote straylight with and without IOL respectively.

### Measuring a commercial intraocular lens

The monofocal Softec HD (Lenstec, Inc., USA) and Tecnis ZCB00 (Advanced Medical Optics) IOL were used with a power of 22.00 D and 24.00 D respectively. The Softec HD lens is a hydrophilic acrylic, aspheric IOL with 5.75 mm optical size. Tecnis ZCB00 is a hydrophobic acrylic IOL with an aspheric surface and 6mm optical diameter. Moreover, the multifocal Tecnis ZM900 (Advanced Medical Optics) with 10.50 D of distance power and 4.00 D addition was evaluated. Tecnis ZM900 is a hydrophobic silicone, aspheric IOL with a diffractive pattern situated on its posterior surface and 6 mm optical diameter.

### Validation of the system

In order to validate the proposed methodology 2 commercially available scattering filters were used: Black Pro Mist (BPM) 1 and 2 (Tiffen, New York, USA). Straylight of both filters have been found to comply with the normal eye and are proposed as validation standard.<sup>6, 21</sup> The filters were evaluated by 3 independent observers along with their own straylight using the unmodified C-Quant. The measured  $\log(s)$  values of the filters were used to calculate an expected straylight increase after their insertion into the system based on the following formula:

$$\text{Expected straylight} = \log(10^{\log(S_{\text{setup}})} + 10^{\log(S_{\text{filter}})}) \quad (3)$$

Each filter and the sum of both (3 different conditions) were placed between  $L_1$  and the wet-cell. Three repeated measurements of the  $\log(s)$ -value were performed for all 3 filter conditions and the C-Quant adaptations without the IOL. The same was done with the IOL present using this formula for the expected straylight value:

$$\text{Expected straylight} = \log(10^{\log(S_{\text{setup+IOL}})} + 10^{\log(S_{\text{filter}})}) \quad (4)$$

Both for setup alone and set-up+IOL 2 observers completed the experiment.

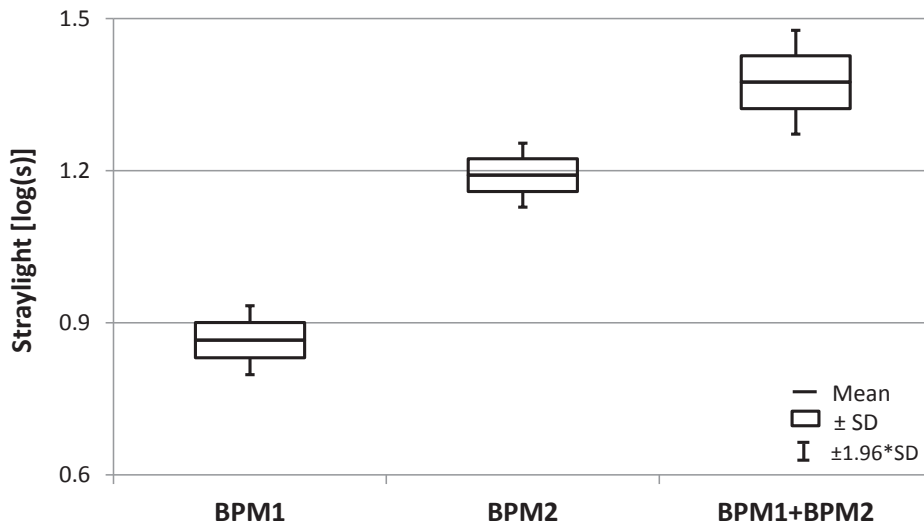

**Figure 4** .Straylight of the BPM filters. The left, middle and right box refer to BPM 1, BPM 2 and the combination of the 2 filters respectively. Each box is based on 9 observations (3 observers, 3 times each).

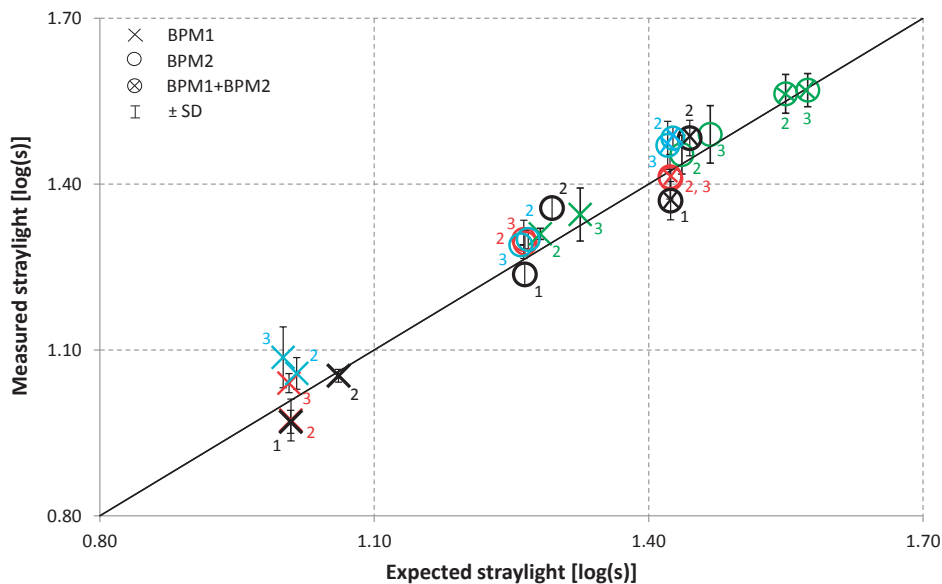

**Figure 5**. Validation of the set-up using the BPM filters. The results measured by observer 1, 2 and 3 (vertical axis) are plotted against the expected straylight values (horizontal axis). The black markers indicate the values of the set-up with filters, without an IOL. The green, red and blue markers refer to measurements of the complete set-up including the Softec HD, Tecnis ZCB00 and Tecnis ZM900 IOL respectively and the BPM samples. Please note that each condition was tested by two observers, each 3 times. Small differences between observers result from the fact that setup straylight differs each time the cuvette is filled.



## RESULTS

The individual straylight values (mean  $\pm$ standard deviation [SD]) of the 3 observers were 0.91  $\pm$ 0.02 log(s), 1.07  $\pm$ 0.02 log(s) and 1.12  $\pm$ 0.03 log(s). Straylight of the filters BPM1, BPM2 and BPM1+BPM2 was 0.87  $\pm$ 0.03 log(s), 1.19  $\pm$ 0.03 log(s) and 1.37  $\pm$ 0.05 log(s) respectively (**Figure 4**). Please note that linear addition of 0.87 log(s) and 1.19 log(s) yields 1.36 log(s), which is very close to the observed value of 1.37 log(s), underlining the additivity rule mentioned above.

A very good absolute correspondence and high correlation ( $R^2=0.97$ ) was observed when measured and expected log(s) were compared using the BMP filters and the set-up with and without the IOLs (**Figure 5**).

The mean difference between the expected straylight value and straylight of the set-up without an IOL as well as with the Softec HD, Tecnis ZCB00 and Tecnis ZM900 IOL was -0.01 log(s), 0.02 log(s), 0.01 log(s) and 0.05 log(s) respectively.

The straylight level of the measured IOLs obtained by the 1<sup>st</sup> and the 2<sup>nd</sup> observer are presented in **Table 1**.

**Table 1.** Straylight of the used IOL models.

IOL Model	Straylight value $\pm$ Standard error [log(s)]	
	Observer 1	Observer 2
Softec HD	0.67 $\pm$ 0.04	0.74 $\pm$ 0.07
Tecnis ZCB00	-0.46 $\pm$ 0.58	-0.61 $\pm$ 0.35
Tecnis ZM900	0.38 $\pm$ 0.07	0.48 $\pm$ 0.05

## DISCUSSION

In the present study, a new methodology to evaluate straylight of IOLs was proposed and tested. The precision of this approach was tested, and a high agreement was found when measurements with standard filters was performed. This technique uses the human eye as an optical detector, capable to establish identity with a good precision. Influence of straylight from other sources could be controlled for. Indeed, the results show that, although the 3 individual straylight values of the observers differ, a close correspondence between the expected and measured results was obtained. This is in line with the study of Van den Berg et al.<sup>6</sup> where 7 light-scattering filters were compared using the C-Quant instrument and 2 other optical methods that involved the use of a CCD camera and photodiode instead of the observer's eye. This study demonstrated that the psychophysical technique is able to provide as accurate results as the optical measurements, since the obtained results were almost identical.

With IOL in the system that scatters light also similar results were obtained when tested with 2 different observers and the 3 filter conditions (**Figure 5**). This indicates that the straylight measurement of IOLs is robust independently from straylight of the eye and the system components. The mean straylight level of the Softec HD IOL was 0.71 log(s), and this might be considered as an increased value if compared to other, non-explanted IOLs studied.<sup>15</sup> The reason of the observed elevation may be that the Softec HD IOL used contained deposits in its material. Since the logarithmic scale was used, the negative straylight values of Tecnis ZCB00 signify that the straylight parameter was less than 1 and that can be considered as functionally unimportant. This is in line with the study of Langeslag<sup>15</sup> where the straylight parameter of the Tecnis ZCB00 IOL was found to be at the tenths level. The evaluation of the multifocal IOL resulted in 0.43 log(s) as mean value. Although, straylight of Tecnis ZM900 has not been measured objectively until now, the found effect is comparable to the previously published data on certain diffractive IOLs.<sup>15</sup>

The C-Quant instrument delivers the straylight parameter of the eye for a fixed visual angle. This might appear as a limitation as one may wonder about the straylight value at smaller or larger angular distances of the glare source. On the other hand, a straylight measurement at the pre-set angle is advantageous when results from different centers are evaluated, or particularly, when the relation between *in vitro* and *in vivo* straylight parameter is sought. This might be beneficial, for instance, when a comparison between scattering of an opacified IOL and the straylight level before its explanation is made.<sup>16, 17</sup> Moreover, there is another reason of using the fixed angle. A series of studies carried out in the 1990s showed that the straylight parameter of the eye is approximately invariant with angle.<sup>8, 9</sup> However, this is applicable only if differences in angle are limited. The relation of log(s) to visual angle has been investigated extensively and proved to follow a parabolic shape with minimum at 7°.<sup>8, 9</sup> An error of 1.5° to either side gives less than 0.03 log of error in log(s). Therefore, while measuring straylight, a small error in observation angle causes only little effect on the straylight value. To perform *in-vitro* straylight measurements of an IOL in a way comparable with that of an IOL implanted in the eye, an optical setup was used to simulate the *in vivo* angle of 8.8° at which light falls onto the crystalline lens of the eye model. The experimental angle was 9.3° and that is 0.5° higher than the calculated *in vivo* value. This difference is acceptable taking into account the above arguments. Therefore, the potential effect of an IOL on straylight of the eye after its explanation/implantation can be predicted. Suppose the presently used Softec HD IOL was removed from an eye that suffered a straylight hindrance of 1.50 log(s). If we assume that a new, implanted IOL does not scatter light, then the expected postoperative, *in vivo* log(s) can be calculated as follows:  $\log(10^{1.50} - 10^{0.71})$  and that gives 1.43 log(s). A similar prediction can be made when this IOL is implanted in an otherwise clear eye with 0.75 log(s)<sup>9</sup>, then an expected postoperative straylight of 1.02 log(s) results.

The methodology of this study can also be applied to measure straylight of other optical elements besides IOLs like contact lenses (CLs). The optical power of CLs might also cause that the unaided observer's eye cannot see correctly the test field when a CL sample is introduced into the system. The presented approach solved this problem using the high-power lens ( $L_2$ ) that can be moved by the observer, and by this, also correcting his/her refractive error. In contrary, straylight of objects that do not present any optical power such as scattering filters<sup>6</sup> or flattened corneal implants<sup>7</sup> can be measured using the unmodified C-Quant instrument. Since the magnification of the test field is not altered, this eliminates the need for using any special lenses and significantly reduces complexity of the system.

In the present study, an adaptation of the C-Quant device for straylight measurements of IOLs was proposed and validated. This methodology used a relatively simple optical set-up that allows to take measurements of the IOL that can be compared to the *in vivo* situation. The methodology is not restricted to IOLs, as it can be employed for assessing straylight of other optical or biological components. The C-Quant delivers a functional parameter which enables a straight comparison between *in vitro* and *in vivo* outcomes, therefore, it can be directly applied in clinical practice and research on light scattering in the human eye.

## REFERENCES

1. Vos JJ. Disability glare - a state of the art report. *Commission International de l'Eclairage Journal* 1984;3:39-53.
2. Vos JJ, Van Den Berg TJ. Report on disability glare. CIE collection 1999;135:1-9.
3. van den Berg TJ, Franssen L, Kruijt B, Coppens JE. History of ocular straylight measurement: A review. *Z Med Phys* 2013;23:6-20.
4. Cerviño A, Montes-Mico R, Hosking SL. Performance of the compensation comparison method for retinal straylight measurement: effect of patient's age on repeatability. *Br J Ophthalmol* 2008;92:788-91.
5. Guber I, Bachmann IM, Guber J, Bochmann F, Lange AP, Thiel MA. Reproducibility of straylight measurement by C-Quant for assessment of retinal straylight using the compensation comparison method. *Graefes Arch Clin Exp Ophthalmol* 2011;249:1367-71.
6. van den Berg TJ, Franssen L, Coppens JE. Straylight in the human eye: testing objectivity and optical character of the psychophysical measurement. *Ophthalmic Physiol Opt* 2009;29:345-50.
7. van Essen TH, Lin CC, Hussain AK, Maas S, Lai HJ, Linnartz H, van den Berg TJ, Salvatori DC, Luyten GP, Jager MJ. A fish scale-derived collagen matrix as artificial cornea in rats: properties and potential. *Invest Ophthalmol Vis Sci* 2013;54:3224-33.
8. I. Jspeert JK, de Waard PW, van den Berg TJ, de Jong PT. The intraocular straylight function in 129 healthy volunteers; dependence on angle, age and pigmentation. *Vision Res* 1990;30:699-707.
9. van den Berg TJ. Analysis of intraocular straylight, especially in relation to age. *Optom Vis Sci* 1995;72:52-9.
10. Van Den Berg TJ, Van Rijn IJ, Michael R, Heine C, Coeckelbergh T, Nischler C, Wilhelm H, Grabner G, Emesz M, Barraquer RI, Coppens JE, Franssen L. Straylight effects with aging and lens extraction. *Am J Ophthalmol* 2007;144:358-63.
11. Van den Berg TJ. On the relation between glare and straylight. *Doc Ophthalmol* 1991;78:177-81.
12. Barbur JIH, A. J.; Williams, C. Light scattered in the eye and its effect on the measurement of the colour constancy index. In: *Colour Vision Deficiencies XIII Proceedings of the Thirteenth Symposium of the International Research Group on Colour Vision Deficiencies, held in Pau, France July 27-30, 1995.* Dordrecht: Doc Ophthalmol Proc Ser 59, 1997.
13. van der Meulen IJ, Gjertsen J, Kruijt B, Witmer JP, Rulo A, Schlingemann RO, van den Berg TJ. Straylight measurements as an indication for cataract surgery. *J Cataract Refract Surg* 2012;38:840-8.
14. Das KK, Stover JC, Schwiegerling J, Karakelle M. Technique for measuring forward light scatter in intraocular lenses. *J Cataract Refract Surg* 2013;39:770-8.
15. Langeslag MJ, van der Mooren M, Beiko GH, Piers PA. Impact of intraocular lens material and design on light scatter: In vitro study. *J Cataract Refract Surg* 2014;40:2120-7.
16. Van der Meulen IJ, Porooshani H, van den Berg TJ. Light-scattering characteristics of explanted opacified Aquasense intraocular lenses. *Br J Ophthalmol* 2009;93:830-2.
17. van der Mooren M, Steinert R, Tyson F, Langeslag MJ, Piers PA. Explanted multifocal intraocular lenses. *J Cataract Refract Surg* 2015;41:873-7.
18. Franssen L, Coppens JE, van den Berg TJ. Compensation comparison method for assessment of retinal straylight. *Invest Ophthalmol Vis Sci* 2006;47:768-76.
19. Franssen L, Coppens JE, van den Berg TJ. Modulation depth threshold in the Compensation Comparison approach. *J Vis* 2007;7:8.
20. Liou HL, Brennan NA. Anatomically accurate, finite model eye for optical modeling. *J Opt Soc Am A Opt Image Sci Vis* 1997;14:1684-95.

21. de Wit GC, Franssen L, Coppens JE, van den Berg TJ. Simulating the straylight effects of cataracts. *J Cataract Refract Surg* 2006;32:294-300.