

The feasibility and efficacy of subcutaneous plerixafor for mobilization of peripheral blood stem cells in allogeneic HLA-identical sibling donors: results of the HOVON-107 study

Georgine E. de Greef,¹ Eric Braakman,¹ Bronno van der Holt,² Jeroen J.W.M. Janssen,³ Eefke Petersen,⁴ Vladimir Vucinic,⁵ Nicole Thuss,² Meriam Grootes,¹ and Jan J. Cornelissen¹

Background: Plerixafor (PFX) mobilizes CD34+ cells into circulation by disrupting the CXCR4 binding of the hematopoietic stem cell in its bone marrow niche.

Study design and Methods: in the prospective HOVON-107 study (www.hovon.nl) 23 allogeneic HLA-identical sibling donors received one or two subcutaneous (sc) injections of plerixafor 0.320 mg/kg. The primary endpoint, was defined as feasibility to mobilize a minimum of 2.0×10^6 CD34+ cells/kg recipient weight obtained by leukopheresis in at least 90% of the donors.

Results: median 3.3×10^6 CD34+ cells/kg (1.9-6.5) were collected after 1 (n=12) or 2 (n=10) sc injections of PFX. Side effects occurred in 15/23 (65%) donors: most were grade 1-2; in 5 donors grade 3 and all resolved. All grafts were directly transplanted. Compared to 10 grafts obtained with G-CSF the number of CD34+ cells was 2.4 fold lower but the percentage of phenotypically most immature CD34+ subset was higher (31% vs 15%). The total number of CD3+ cells in the graft seemed higher after PFX-mobilization, but CD4/CD 8 ratios, and frequencies of Th2, Th17 and regulatory T-cells or NK cells were comparable. All patients engrafted and no increase in incidence or severity of acute or chronic graft versus host disease was observed.

Conclusion: stem cell mobilization with sc PFX 0.320 mg/kg in allogeneic sibling donors is feasible with limited toxicity for donors. 14 allogeneic donors were mobilized with PFX 0.320 mg intravenously according to the same protocol. Due to the limited numbers, these results are in the supplementary section.

The mobilization of hematopoietic stem and progenitor cells (HSPCs) in allogeneic human leukocyte antigen (HLA)-identical sibling donors with subcutaneous (SC) injections of granulocyte-colony stimulating factor (G-CSF) is standard practice.¹ In most donors, this results in a sufficient number of CD34+ cells for subsequent transplantation. However, it requires the administration of one to two daily SC injections for a period of 4 to 6 days, and side effects of G-CSF have been

ABBREVIATIONS: ANC = absolute neutrophil count; CI = confidence interval; CXCR4 = chemokine receptor 4; G-CSF = granulocyte-colony stimulating factor; GvHD = graft-versus-host disease; HLA = human leukocyte antigen; HSPCs = hematopoietic stem and progenitor cells; IV = intravenous; NK = natural killer; PFX = plerixafor; SC = subcutaneous.

From the ¹Department of Hematology, Erasmus MC Cancer Institute, Rotterdam, Netherlands; ²Department of Hematology, HOVON Data Center, Erasmus MC, Rotterdam, Netherlands; ³Department of Hematology, VU University Hospital, Amsterdam, Netherlands; ⁴Department of Hematology, UMC Utrecht, Utrecht, Netherlands; and the ⁵Department of Hematology, Clinical Oncology and Hemostaseology, University of Leipzig, Leipzig, Germany.

Address reprint requests to: G.E de Greef, Erasmus MC Cancer Institute, Department of Hematology, PO Box 2040, 3000 CA Rotterdam, The Netherlands; e-mail: g.degreef@erasmusmc.nl

This is an open access article under the terms of the Creative Commons Attribution-NonCommercial License, which permits use, distribution and reproduction in any medium, provided the original work is properly cited and is not used for commercial purposes.

This study was financially supported by Genzyme/Sanofi and registered at www.trialregister.nl as NTR2929, EudraCT 2010-023436-16.

Received for publication April 19, 2018; revision received August 31, 2018; and accepted August 31, 2018.

doi:10.1111/trf.15037

© 2018 The Authors. *Transfusion* published by Wiley Periodicals, Inc. on behalf of AABB.

TRANSFUSION 2018;00;1-9

reported in the majority of healthy donors with the following median frequencies: bone pain, 70% to 86%; headache, 40%; myalgias, 36%; fatigue, 20%; nausea/vomiting, 10%; and fever, 3%.² Often, this requires the use of medication such as paracetamol and causes discomfort, with an effect on daily life and/or work. Administration of G-CSF can induce a transient increase in spleen size; in some donors, a rupture of the spleen has been reported.²⁻⁴ Considering this, another way of effective mobilization with fewer side effects could be of advantage.

HSPCs express the chemokine receptor 4 (CXCR4). Plerixafor (PXF) is a small bicyclam molecule that reversibly binds and blocks CXCR4. This results in inhibition of the binding with its ligand stroma cell-derived factor-1, also known as C-X-C motif chemokine-12, and causes the direct release of HSPCs from their niches in the bone marrow stroma into the circulation.⁵ Two randomized controlled Phase III trials in patients with multiple myeloma and non-Hodgkin lymphoma showed that addition of PXF to G-CSF led to significantly higher numbers of CD34+ cells in first mobilization procedures.^{6,7} Several compassionate use programs in the United States and Europe emphasized the favorable role of PXF in patients with mobilization failure after G-CSF, showing success rates of 60% to 80% with PXF. These studies resulted in approval by the Food and Drug Administration and European Medicines Agency of PXF in combination with G-CSF for its use in patients who fail to mobilize autologous stem cells.⁸ However, data on the use of PXF in allogeneic stem cell donors are limited.

In the study of Devine et al.,⁹ 25 sibling donors received 0.24 mg/kg PXF SC. At least 2×10^6 /kg CD34+ cells were collected in 22 of 24 donors after one (16 of 24) or two (6 of 8) SC injections. One donor mobilized 1.9×10^6 /kg, which was used for transplant with successful engraftment. Following transplantation after myeloablative conditioning (20 patients), engraftment was rapid and complete in all patients with median time to absolute neutrophil count (ANC) greater than 0.5×10^9 /L of 10 days (range, 8-13 days) and median time to platelet counts greater than 50×10^9 /L of 18 days (12-32). Most donors observed only mild side effects (Grade 1), that were reported directly after administration of PXF: lightheadedness (40%); nausea, bloating, or flatulence (36%); injection site discomfort, warm sensation (28%); perioral paresthesias, loose stools, or diaphoresis (20%); and headache (16%). One donor complained about Grade 2 pain at the injection site. All toxicities resolved in a few days. Although a high number of CD3+ and CD4+ T cells were present in grafts mobilized with PXF, this was not associated with a high incidence of graft-versus-host disease (GvHD) in the transplanted patients. The intravenous (IV) administration of PXF 0.320 mg/kg followed by leukapheresis 4 hours later resulted in the collection of at least 2×10^6 CD34+ cells in 19/29 HLA-identical sibling donors.¹⁰ In seven donors, this target was reached after a second IV injection.

Adverse effects after IV administration of PXF seemed comparable to the side effects after SC injection. Grade 1 abdominal discomfort (30%) and bradycardia (30%) were most common. No Grade 3 or 4 adverse effects occurred. PXF has not been studied prospectively in daily practice of donor mobilization and subsequent allogeneic transplant. Therefore, the primary aim of the current study was to assess the feasibility and side effects of PXF 0.320 mg/kg SC to mobilize sufficient HSPCs in HLA-identical sibling donors and to determine engraftment in the transplanted patients. Also chimerism, immune reconstitution, and incidence of GvHD were analyzed. Finally, kinetics of CD34 cell mobilization as well as the composition of the stem cell graft with respect to numbers of HSPCs, T cells, T-cell subsets, and regulatory T cells were investigated.

MATERIALS AND METHODS

The present HOVON-107 study (www.hovon.nl) started as a Phase 2 prospective, randomized study in allogeneic HLA-identical sibling donors and patients. The primary endpoint was the feasibility of PXF 0.320 mg/kg SC (arm A) or IV (arm B) to mobilize at least 2.0×10^6 CD34+ cells/kg receiver weight for transplant. Feasibility was defined as a minimum of 2.0×10^6 /kg CD34+ cells after one or two doses of PXF and subsequent leukapheresis in at least 90% of the donors. Interim analysis after 10 donors in each of the two arms concluded it was safe to continue. Unfortunately, accrual was not as expected. Moreover, it appeared that IV administration followed by leukapheresis 4 hours later resulted in very long hours for donors, collection centers, and stem cell laboratories. For both reasons, it was decided to close the IV arm and to continue with the SC arm only. The current paper describes the characteristics and results for 23 donor/patient pairs (arm A). The number of 14 IV donors and patients (arm B) is considered too small to conclude about feasibility of IV PXF. Therefore, the results for this group are found in Appendix S1, available as supporting information in the online version of this paper. For the flow diagram of donors, see Fig. 1.

After written informed consent, donors received PXF 0.320 mg/kg as a single SC injection 9 hours before the planned stem cell collection. In case the absolute number of CD34+ cells in the harvest was less than 2.0×10^6 /kg recipient weight, a second injection of PXF was administered and stem cells collected the following day. The leukapheresis procedure should process 15 L of peripheral blood. It was advised to transplant grafts containing 1×10^6 CD34+ cells/kg or greater after two mobilizations. In case less than 1×10^6 CD34+ cells/kg were collected after two mobilizations, it was strongly advised that bone marrow cells should be harvested from the donor the following day by multiple punctures under general anesthesia.

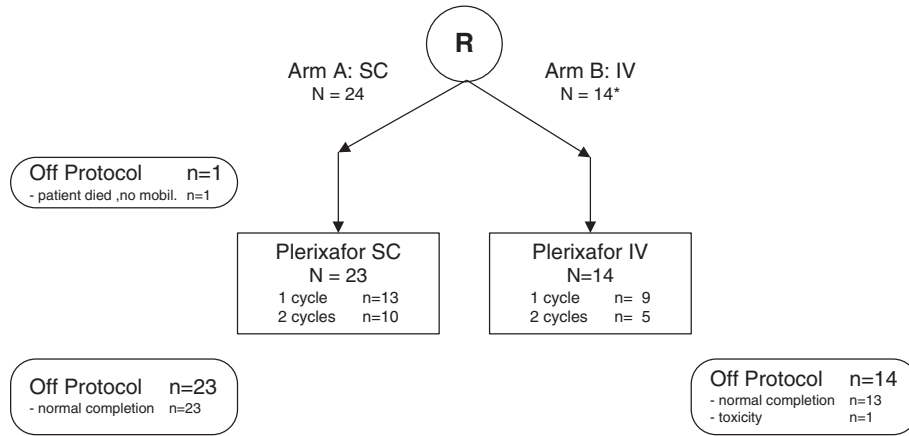

Fig. 1. Flow diagram of the inclusion of donors/patients in the HOVON-107 study.

Inclusion criteria for donors were age 18 to 60 years inclusive; hematologic parameters within normal limits; and capability of undergoing leukapheresis and adequate venous access. All donors consented to insertion of a peripheral venous catheter and bone marrow collection if necessary. A negative pregnancy test at study entry for women of child-bearing potential was mandatory. Also, all donors agreed to use adequate contraception during the mobilization period and up to 3 months after last dose of PXF. In addition, donors should fulfill standard criteria for donor eligibility. Donors with unstable hypertension requiring more than one medication were excluded. Ultrasonography of the spleen was performed before the administration of PXF and repeated directly after the stem cell collection. For donor characteristics see Table 1A.

Patients were included after written informed consent. Indication for allogeneic stem cell transplant was determined by each participating center according to local criteria. Age for inclusion was 18 to 65 years inclusive. For patients with a myelodysplasia with International Prognostic Scoring System score of 1.5 or greater, acute myeloid or lymphatic leukemia, a first complete remission was required. For all patients, the World Health Organization performance score should be 2 or less and life expectancy greater than 3 months. Transplants and GvHD prophylaxis were performed according to institutional guidelines. For patient characteristics see Table 1B. The absolute number of viable CD34+ cells was determined by flow cytometry using a stem cell enumeration

kit (Beckman Coulter) according to the manufacturer’s instructions and the single platform flow cytometry International Society of Hematotherapy and Graft Engineering gating strategy in blood of the donor obtained just before administration of PXF; at 2, 4, and 6 hours after PXF administration; just before initiating apheresis; and after 5, 10, and finally 15 L of blood had been processed.^{11,12}

During apheresis, the number of CD34+ cells in the graft was also determined after 5, 10, and 15 L processed blood volume. The composition of PXF-mobilized hematopoietic progenitor cells, apheresis products obtained after the first stem cell collection, was evaluated by flow cytometry. The absolute number of CD34+ cells was determined as described above. To assess the frequency of lin-CD38^{low}/CD45RA⁻/CD90+ phenotypic hematopoietic stem cells and CD19+ pre-/pro B cells within the CD34+ population, cells were stained with lineage fluorescein isothiocyanate,

TABLE 1A Donor characteristics	
n = 23	
Age [y], median (range)	47 (24–60)
Male/female	16/7
WHO 0	23
Hb [mmol/L], median (range)	9.0 (7.7-10.7)
WBC [× 10 ⁹ /L], median (range)	6.1 (4.0–10.7)
Platelets [× 10 ⁹ /L], median (range)	226 (130–318)
Spleen size [cm], median (range)	11 (7–13) (n = 21)

TABLE 1B Patient characteristics	
n = 23	
Age	50 (21–64)
Male/female	17/6
WHO 0	9
WHO 1	10
WHO 2	4
AML/MDS	9
ALL	4
MM	4
Lymphoma	4
CLL	2
Stage of disease at transplant	
CR	12
PR	7
SD	4
Nonmyeloablative SCT	17
Myeloablative SCT	6
ALL = acute lymphoblastic leukemia; AML = acute myeloid leukemia; CLL = chronic lymphocytic leukemia; CR = complete remission; Hb = hemoglobin; MDS = myelodysplastic syndrome; MM = Multiple Myeloma; PR = Partial remission; SD = Stable disease; SCT = stem cell transplant; WHO = World Health Organization.	

CD34-Pe-Cy7, CD19-APC, CD38-PE-Cy5, CD45RA-APC-H7, and CD90-PE. The absolute number of CD3+, CD3+/CD4+, CD3+/CD8+, CD3-/CD16+/CD56+, and CD19+ cells in the graft was assessed using four-color direct immunofluorescence reagent kits (Becton Dickinson). The frequency of T helper cells (Th1, Th2, Th17) within the CD4+ T cells was assessed using a phenotyping kit (Human Th1/Th2/Th17 Phenotyping kit, Becton Dickinson) according to the manufacturer's instructions. The frequency of Foxp3+ Treg within CD4+ cells was analyzed by intracellular staining using an antihuman staining set (Foxp3, e-Bioscience) after fixation and permeabilization of peripheral blood cells according to the manufacturer's instructions.

Results were compared to 10 G-CSF-mobilized hematopoietic progenitor cells, apheresis products obtained from healthy adult sibling donors previously mobilized with G-CSF 10 µg/kg during 5 days. For chimerism analysis, DNA was isolated from peripheral blood cells, peripheral blood T cells and bone marrow cells using a blood genomic prep mini spin kit (Illustra, GE Healthcare) according to the manufacturer's instruction. T lymphocytes were purified from peripheral blood using a human whole blood CD3 positive selection kit (STEMCELL Technologies, Inc.) according to the manufacturer's instructions. Chimerism analysis was performed by polymerase chain reaction amplification of five informative STR loci at 3, 6, 12, and 24 months after transplantation. The resulting labeled polymerase chain reaction products were size fractionated by capillary electrophoresis and quantified.

In the patients, immunological reconstitution was determined at 3, 6, and 12 months after transplantation. Absolute numbers of T, B, and natural killer (NK) cells as well as the CD4 and CD8 subpopulations of T cells in peripheral blood were determined by a single-platform flow cytometric assay using four-color direct immunofluorescence reagent kits (Becton Dickinson) and fluorophores to determine absolute counts on a flow cytometer (Beckman Coulter). All flow cytometric analyses were performed using a cell analyzer (FACSCalibur, Becton Dickinson). Flow cytometric data were collected and analyzed using computer software (CELLQuest, Becton Dickinson).

Statistical analysis

The study was originally designed as a randomized, multicenter phase II trial with two treatment arms, i.e., mobilization with either PXF SC (arm A) or IV (arm B). The aim of the study was to assess the feasibility of each of the two arms separately, as defined before. For each treatment arm, the optimal Simon 2-stage design was applied.¹³ However, a formal comparison between the two arms would not be applied. In each of the two arms, a true percentage of 70% successful harvests would be considered insufficient, while 90% or more would be desirable and warrant further investigation of the arm(s). With $\alpha = 0.10$ and $\beta = 0.20$, a sample size of 28 patients per arm would be required, with

an interim analysis after the first 9 donors. At the final analysis at least 23 of 28 successful had to be observed in one arm to conclude that the arm would be feasible. Because of slow accrual, the trial was amended to continue only with arm A.

The estimated rate of donors with 2.0×10^6 or more CD34+ cells/kg recipient weight after one or two harvests would be calculated along with the 90% confidence interval (CI). Continuous variables were summarized by median and range. Adverse events were scored according to the National Cancer Institute's Common Terminology Criteria for Adverse Events, version 4.0, separately for donors and patients. Progression-free and overall survival rates were estimated by the Kaplan-Meier method, and 95% CIs were constructed. Kaplan-Meier survival curves were generated to illustrate progression-free survival and overall survival.

RESULTS

The results for the SC administration of PXF are shown below. The results for the IV administration are found in Appendix S1, available as supporting information in the online version of this paper. Between August 2012 and January 2017, a total of 24 donors were included in the PXF SC arm. One donor was not treated because the patient had already died. For donor characteristics see Table 1. Twenty-three donors received PXF 0.320 mg/kg SC, median 9.7 hours (range, 8–10.7), before the planned stem cell collection. In 12 donors, this resulted in 2×10^6 /kg or more recipient weight CD34+ cells. In one donor 1.9×10^6 /kg CD34+ cells was considered sufficient for transplant. Ten of 23 donors needed a second SC injection and stem cell collection. Finally, median $3.3 (1.9-6.5) \times 10^6$ /kg recipient weight CD34+ cells were collected in all 23 donors and transplanted. These 23 donors and patients were required to consider the SC PXF arm feasible. As the primary endpoint had been achieved, it was decided to close the trial.

Side effects related to PXF occurred in 15 of 23 (61%) donors with the majority Grade 1 or 2 (Table 2). Common

TABLE 2 Adverse events after PXF 0.32 mg/kg SC

Adverse event	Grade 1	Grade 2	Grade 3
Clotting during apheresis	–	–	3
Tingling	4	3	–
Nausea/vomiting	3	3	–
Flulike/fatigue	1	4	1
Headache	3	–	–
Abdominal discomfort/diarrhea	1	2	–
Decreased platelets	–	3	1
Dizziness	2	1	–
Flushing	1	1	–
Left flank pain	1	–	–
Hypotension	–	1	–
Arm pain	1	–	–

Adverse events were scored according to the National Cancer Institute's Common Terminology Criteria for Adverse Events, version 4.0.

Terminology Criteria for Adverse Events Grade 3 side effects were clotting during the leukapheresis procedure in two donors, decrease of platelets in one donor, and fatigue after the mobilization procedure in one donor. Grade 3 hypokalemia and syncope were observed each in one donor but considered not related. All side effects resolved. No Grade 4 adverse effects were reported. Stem cell collection was performed by leukapheresis with an apheresis system (Spectra Optia, Terumo BCT) in 18 donors and Cobe Spectra (Terumo BCT) in 5 donors. The volume of processed blood was median 14.6 (9.1–23.1) L. In 10 donors in which a second collection was performed, a median of 13.4 (7.0–23.1) L of blood was processed. One donor needed an inguinal central catheter due to clotting during the first procedure. Spleen sizes in 23 donors determined by ultrasound were found to be within normal range at the start: median 11 (10–12) cm, and within similar range the day after PXF: median 11 (10–12) cm. The steady state CD34+ cell number in peripheral blood before the first PXF administration was low, that is, median $3 (1-5) \times 10^6$ CD34+ cells/L. At 2 hours after SC administration of PXF, an increase of CD34+ cells in blood was apparent: median $13 (5.9-50) \times 10^6$ /L. At 4 and 6 hours after PXF the CD34+ cell levels were only slightly higher: median $20 (9.6-49) \times 10^6$ /L and median $20 (11-58) \times 10^6$ /L, respectively.

At the start of stem cell collection, 8 to 11 hours after the administration of PXF, CD34+ cells in the peripheral blood were median $26.1 (8.5-71.1) \times 10^6$ /L (Fig. 2A). During the apheresis procedure, the numbers of CD34+ cells in the peripheral blood initially dropped but did not change much thereafter. After 5 L of processed blood volume, the CD34+ cells were median $18 (10-52) \times 10^6$ /L; after 10 L, $16 (6.9-46) \times 10^6$ /L; and after 15 L, median $15.9 (5.7-47.5) \times 10^6$ /L. The amount of CD34+ cells in the grafts after 5, 10, and 15 L of processed blood volume were median $0.6 (0.2-2.6)$, $1.4 (0.6-3.4)$, and $2.1 (1.1-6.6) \times 10^6$ /kg receiver weight, respectively (Fig. 2B,C). The grafts obtained after a single SC injection of PXF contained a median of $194 (79-548) \times 10^6$ CD34+ cells (Table 3). Within the CD34+ cell population, 31% showed the phenotype of the primitive hematopoietic stem cell: (lin- CD34+/CD38^{low}/ CD45RA-/CD90+) and 55% had the phenotype of the more committed multipotent/common myeloid progenitor cells (CD34+/CD45RA+/CD90-). A small percentage of CD34+ cells coexpressed CD19 (2.85%). The 10 G-CSF mobilized grafts contained a median of 438×10^6 (356–840) CD34+ cells, of which 15% were phenotypic hematopoietic stem cells and 77% phenotypic multipotent/common myeloid progenitor cells. The fraction of CD34+/CD19+ cells was 2%. Grafts obtained after PXF mobilization contained more CD3+ cells: median $22.6 (10.6-56.7) \times 10^9$ compared to G-CSF (CD3+ cells: median $12.8 (7.6-21) \times 10^9$). The CD4/CD8 ratios were comparable, as well as the frequencies of IL-4+/ CD4+ Th2 cells; IL-17+/CD4+/Th17 cells and CD4+/Foxp3+ regulatory T-cells. Also, the numbers of CD3-/CD16+/CD56+ NK cells were similar both after PXF and G-CSF.

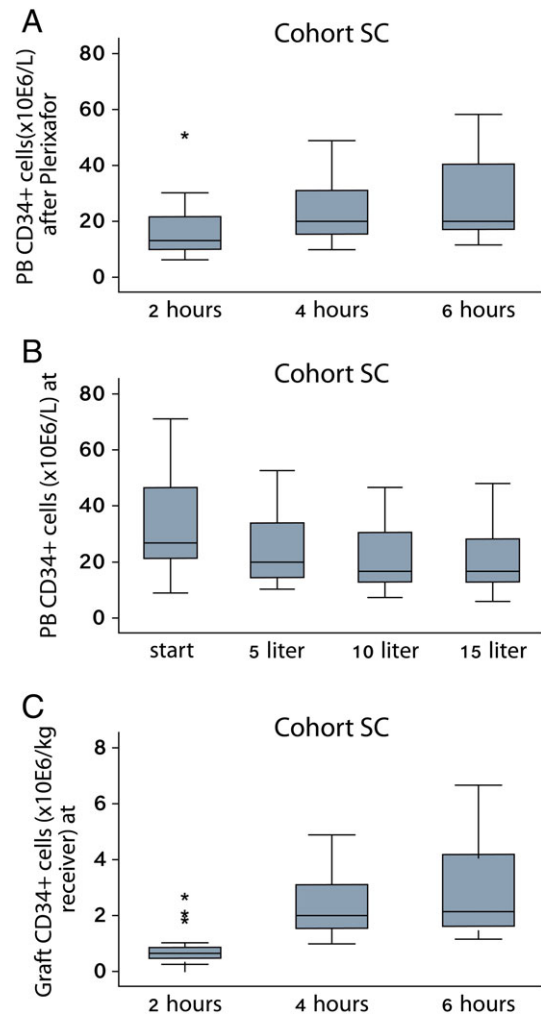

Fig. 2. (A) Appearance of CD34+ cells in the peripheral blood (PB) 2, 4, and 6 hours after SC administration of plerixafor 0.23 mg/kg. (B) CD34+ cells were analyzed at start and during stem cell apheresis after 5, 10, and 15 L of processed blood volume in the peripheral blood and (C) in the stem cell graft. Each box is drawn from the 25th percentile to the 75th percentile of the CD34+ counts, and the horizontal bar within the box indicates the median CD34+ count. The lineup from the top of the box goes to the upper adjacent value.¹⁴ The dots indicate CD34+ counts larger than the upper adjacent value. [Color figure can be viewed at wileyonlinelibrary.com]

The number of CD19+ B cells in the PXF-mobilized grafts appeared twice as high as in G-CSF-mobilized grafts.

All 23 patients were directly transplanted with the PXF mobilized grafts. Conditioning was myeloablative in 6 patients and nonmyeloablative in 17 patients. GvHD prophylaxis was given according to local protocol. One patient received cyclophosphamide following transplantation. All patients engrafted and recovered, with ANC greater than 0.5×10^9 /L median on Day 17 (0–27) and platelets greater than 50×10^9 /L on Day 13 (0–23). Acute GvHD was observed in

TABLE 3 Composition of the grafts obtained from healthy adult sibling donors

	PXF SC	%*	G-CSF	%*
N	23		10	
CD34+ × 10 ⁶	194 (79–548)		438 (356–840)	
CD 34+/CD45RA-/CD90+ × 10 ⁶	49 (4–211)	31.3%	65 (11–200)	15%
CD 34+/CD45RA-/CD90- × 10 ⁶	133 (20–428)	55%	312 (195–572)	77%
CD34+/CD 19+	5.1 (1.8–27.6)		2.1 (0.0–4.3)	
CD3 × 10 ⁹	22.6 (10.6–56.7)		12.8 (7.6–21)	
CD3/CD4 × 10 ⁹	14.8 (6.1–30.5)		7.5 (4.3–15.4)	
CD3/CD8 × 10 ⁹	7.2 (2.7–22.1)		3.8 (2.0–6.0)	
CD 4/8 ratio	1.7 (1.1–5.2)		1.6 (1.0–5.5)	
CD3-/CD16+/CD56+ × 10 ⁹	1.9 (0.5–6.90)		1.3 (0.5–2.9)	
CD19+ × 10 ⁹	6.3 (2.7–18.1)		3.1 (1.9–4.5)	
Fox P3, %	6.3 (2.7–10.4)		5.8 (2.6–10.9)	
Th1, %	24.4 (3.0–40.7)		16.6 (2.5–27.5)	
Th2, %	2.5 (0.4–7.5)		2.3 (0.5–4.4)	
Th17, %	1.3 (0.2–25.9)		1.4 (0.2–5.0)	

23 PXF mobilized grafts were obtained after a single injection of 0.32 mg/kg SC PXF. Ten G-CSF mobilized grafts were obtained after injection of G-CSF 2 × 5 µg/kg SC during 5 days.

* Percentage of total number of CD34+ cells.

G-CSF = granulocyte-colony stimulating factor; N = number; PXF = plerixafor; SC = subcutaneous; Th = T helper cell.

6 of 23 patients: 2 patients, Grade 3; 1 patient, Grade 2; and 3 patients, grade 1. One patient died of steroid-refractory GvHD. Chronic extensive GvHD was present in 7 of 23 patients, and limited GvHD in 3 of 23. The latter involved liver and mouth in all patients, skin in 3, eyes in 2, and lungs in 1 patient. At 12 months, it was ongoing in 4 patients. Overall survival and progression-free survival at 12 months were 72% (95% CI, 49%–87%) and 55% (95% CI, 32%–73%). Eight of 23 patients died: 5 because of disease progression, 2 with infection, and 1 with GvHD. Median follow-up of patients still alive is 24 months (6–26).

With respect to chimerism at 3 months, 11 of 16 patients with available data showed full donor chimerism in the peripheral blood. For bone marrow and CD3, this was found in 13 of 15 and 5 of 14 patients. At 12 months, all analyzed patients had complete donor hematopoiesis in all fractions (Table 4). Data on immunologic reconstitution of 16 of 23 transplant recipients showed CD3/CD8 cells and NK cells at normal range 3 months after transplantation.

Numbers of CD3+ cells, CD3+ /CD4+ cells and CD19+ cells showed a gradual increase and were within normal range at 12 months (Fig. 3).

DISCUSSION

The current study shows that PXF 0.320 mg/kg SC has activity as a mobilizing agent in allogeneic HLA-identical sibling donors: All 23 donors mobilized sufficient CD34+ cells for transplant after one or two injections. The failure rate of 48% after the first injection is somewhat higher compared to other studies: Most describe failure rates around 30% to mobilize at least 2 × 10⁶ CD34+ cells with a single SC or IV injection PXF (Table 5). As peak CD34+ cells in the blood appeared higher with a single dose of 0.480 mg/kg PXF IV, it was suggested that this dose might improve the failure rates.¹⁵ However, in this study, no subsequent stem cell collection was performed. Although the total number of CD34 + cells after

TABLE 4 Chimerism in peripheral blood (PB), bone marrow (BM), and CD3 selected cells at 3, 6, and 12 months after transplant

	N		PB	%*	BM	%*	CD3	%*
3 months	20	Complete	13	81%	13	87%	6	40%
		Incomplete	3		2		9	
		nd	4		5		5	
6 months	17	Complete	11	100%	10	91%	9	75%
		Incomplete	0		1		3	
		nd	6		6		5	
12 months	11	Complete	4	100%	3	100%	5	100%
		Incomplete	0		0		0	
		nd	7		8		6	

N = number of patients that were still progression free and alive at each of the time points. Complete ≥95% donor cells. Incomplete <95% donor cells.

* Percentage of patients with available data.

nd = not done

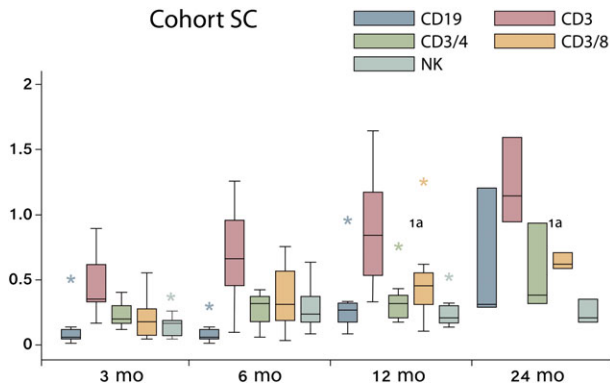

Fig. 3. Immunologic reconstitution. Numbers of CD3+; CD3+/CD4+; CD3 + CD8+; CD19+, and NK cells in the peripheral blood at 3, 6, 12, and 24 months after transplant. At 12 months: CD3 + cells: median, $0.84 \times 10^9/L$ (0.33–1.65); normal range, 0.66–2.10. CD3+/CD4+ cells: median, $0.30 \times 10^9/L$ (0.17–0.75); normal range, 0.32–1.36. CD3+/CD8+ cells: median, $0.45 \times 10^9/L$ (0.11–1.24); normal range, 0.15–0.88. CD3–/CD16+/CD56+ NK cells: median, $0.20 \times 10^9/L$ (0.13–0.52); normal range, 0.09–0.62. CD19+ cells: median, $0.27 \times 10^9/L$ (0.09–0.95); normal range, 0.10–0.5. Each box is drawn from the 25th percentile to the 75th percentile of the cell counts, and the horizontal bar within the box indicates the median cell count. The line up from the top of the box goes to the upper adjacent value as defined.¹⁴ The dots indicate cell counts larger than the upper adjacent value. [Color figure can be viewed at wileyonlinelibrary.com]

PXF was 2.4-fold lower compared to G-CSF, the percentage of lin-CD34⁺/CD38^{low}/CD45RA⁻/CD90⁺ cells was almost twice as high (31% vs. 15%). Therefore, PXF preferentially mobilizes the most primitive phenotypic HSC.¹⁶

Recent studies showed also that PXF seems to mobilize a more primitive unique population of CD34^{dim}/CD45 RA⁺ cells that appeared to be plasmacytoid progenitor cells^{16–18} and CD34^{dim}/CD45RA⁺/CD123⁺⁺ plasmacytoid dendritic cell precursors.¹⁰ The meaning of this finding with respect to immune function in the transplant recipient is not known yet. In our study, we did not look specifically at these plasmacytoid dendritic cells. Our study is the largest study in the allogeneic setting that directly transplanted the PXF mobilized grafts, resulting in quick engraftment both for neutrophils and platelets. This holds also for the grafts obtained with IV PXF. Although chimerism data are limited, they suggest complete donor hematopoiesis in all fractions at 12 months. In accordance with previous reports, grafts obtained with PXF contained more CD3⁺ cells.^{9,10}

Alloreactive CD4⁺ T cells and their cytokines are associated with acute GvHD but their relation with chronic GvHD is less straightforward.^{19,20} For the latter, both regulatory T cells and CD19⁺ B cells and T-follicular helper cells are believed to play a role.^{21,22} We did not look at the T-follicular helper cells but the frequencies of regulatory T cells in the grafts were similar with PXF or G-CSF. The occurrence of acute (2 patients grade 3) and chronic extensive GvHD at 120 days (7 of 17 patients at risk [30%]) appears to be as expected in the setting of non-T-cell-depleted transplantation.^{23–26} The immunologic reconstitution improved gradually and was almost within normal range 12 months after transplantation. For comparison, no differences in absolute numbers in blood of CD3, CD3/CD4, CD3/CD8, and NK cells were observed 3, 6, and 12 months after transplantation in 20 patients who received G-CSF mobilized HSCs in the same period (data not shown). This is in accordance with earlier reports.²⁷ Numbers of CD19⁺ cells appeared higher in PXF mobilized grafts. Interestingly,

TABLE 5 Studies with plerixafor in allogeneic donors

Study reference/year	n	Dose mg/kg	Failure after 1 gift	Proc. Vol. ltrs.	CD34 × 10 ⁶ /kg* Med (range)	Direct trans-plant	Eval pts	Engraftment median day (range)
Devine ⁹ 2008	25	0.240 SC	33%	20	2.9 (1.2–6.3)	No	20	ANC 10 (8–13) [†] Plt 18 (12–32) [‡]
Gattillo ²⁸ 2015	10	0.35 SC (0.24–0.47)		15–20	2.8 (1.1–4.3)	yes	10	ANC 17 (15–25) Plt 18 (10–101) [§]
Schroeder ¹⁰ 2017	21	0.240 SC	33%	20	3.5 (1.9–19.7)	No	18	ANC 10 (9–12) [†] Plt 33 (19–70) [‡]
Schroeder ¹⁰ 2017	29	0.320 IV [¶]	34%	17.9 (3.7–20)	2.9 (2.0–9.7)	No	33	ANC 14 (11–27)** Plt 25 (15–219) ^{‡,**}
H-107 study 2018	23	0.320 SC	48%	14.6 (9.1–23.1)	3.3 (1.9–6.5)	Yes	23	ANC 17 (0–27) Plt 13 (0–23) [‡]

* Recipient weight (kg).

† G-CSF started on day 1.

‡ Engraftment defined as: ANC > 0.5 × 10⁹; and platelet > 50 × 10⁹.

§ Engraftment defined as: ANC > 0.5 × 10⁹; and platelet > 20 × 10⁹.

|| Plerixafor was administered to eight donors with inadequate graft after G-CSF.

¶ After the first dose escalation part of the study, a second gift plerixafor was administered after a wash out of 4 days.

** GvHD prophylaxis included methotrexate.

ANC = absolute neutrophil count; Eval pts = number of evaluable patients; G-CSF = granulocyte-colony stimulating factor; GvHD = graft-versus-host disease; IV = intravenous; Plt = platelet; Proc. Vol = processed blood volume by leukapheresis; SC = subcutaneous.

in the PXF-transplanted patients, the numbers of CD19+ cells 12 months after transplantation also seemed higher compared to G-CSF, but numbers are small. The kinetics data suggest that mobilization of CD34+ cells starts within 2 hours after administration of SC PXF and continues during the apheresis procedure, that is, until 14 hours after administration of PXF. A recent study showed a similar pattern with 0.240 mg/kg and 0.480 mg/kg of PXF SC.¹⁵ Considering this long period with CD34+ cells present in the peripheral blood, a large-volume apheresis might be useful in donors who are mobilized with PXF. This could also reduce the number of injections.

The use of SC PXF is certainly associated with side effects in the majority of donors. Diarrhea, vomiting, nausea, and tingling were most frequently reported. However, these were all Grade 1 to 2 and resolved completely. This is in agreement with earlier studies with PXF in both patients and donors.^{6,7,9} Common Terminology Criteria for Adverse Events Grade 3 adverse events were reported in 3 of 23 donors: clotting during the leukapheresis, fatigue, and hypokalemia. Our study included donor follow-up for 2 years and is still running for this part. These results will be reported. Although the results after SC and IV administration formally cannot be compared, we have the impression that no major differences seem apparent. Although infusion of PXF and stem cell collection in 1 day seems attractive, this will mean long hours for donors and collection centers, especially when large-volume apheresis is performed. Therefore, we would favor the use of SC PXF in allogeneic donors. Based on the now available data, we consider stem cell mobilization in allogeneic donors with one or two SC injections with PXF 0.320 mg/kg feasible. Indeed, stem cell mobilization with PXF is accompanied by side effects, mainly Grade 1 or 2. On the other hand, this counts also for the SC administration of 10–12 injections of G-CSF, with side effects often requiring medication.² A future prospective randomized study comparing both G-CSF and PXF SC for stem cell mobilization in adult HLA-identical donors including cost-effectiveness and quality-of-life studies would be helpful.

ACKNOWLEDGMENTS

The authors thank E.C.M.M. Simons for preparing the figures.

CONFLICT OF INTEREST

G.E.d. G. and E.J.P. are members of the Sanofi Advisory Board in the Netherlands. V.V. is a member of the Sanofi Advisory Board in Germany. The remaining authors have disclosed no conflicts of interest.

REFERENCES

1. Champlin RE, Schmitz N, Horowitz MM, et al. Blood stem cells compared with bone marrow as a source of hematopoietic cells for allogeneic transplantation. IBMTR Histocompatibility and Stem Cell Sources Working Committee and the European Group for Blood and Marrow Transplantation (EBMT). *Blood* 2000;95(12):3702.
2. D'Souza A, Jaiyesimi I, Trainor L, et al. Granulocyte colony-stimulating factor administration: adverse events. *Transfusion Med Rev* 2008;22(4):280.
3. Stroneck D, Shawker T, Follmann D, et al. G-CSF-induced spleen size changes in peripheral blood progenitor cell donors. *Transfusion* 2003;43(5):609.
4. Becker P, Wagle M, Matous S, et al. Spontaneous splenic rupture following administration of granulocyte colony-stimulating factor therapy in an allogeneic blood stem cell donor. *Biol Blood Bone Marrow Transplant* 1997;3(1):45.
5. Uy G, Rettig MP, Cashen AF. Plerixafor, a CXCR4 antagonist for the mobilization of hematopoietic stem cells. *Expert Opin Biol Ther* 2008;8(11):1797.
6. DiPersio JF, Stadtmauer EA, Nademanee A, et al. Plerixafor and G-CSF versus placebo and G-CSF to mobilize hematopoietic stem cells for autologous stem cell transplantation in patients with multiple myeloma. *Blood* 2009;113(23):5720.
7. DiPersio JF, Micallef IN, Stiff PJ, et al. Phase III prospective randomized double-blind placebo-controlled trial of plerixafor plus granulocyte colony-stimulating factor compared with placebo plus granulocyte colony-stimulating factor for autologous stem-cell mobilization and transplantation for patients with non-Hodgkin's lymphoma. *J Clin Oncol* 2009;27(28):4767.
8. Mohty M, Hubel K, Kroger N, et al. Autologous haematopoietic stem cell mobilisation in multiple myeloma and lymphoma patients: a position statement from the European Group for Blood and Marrow Transplantation. *Bone Marrow Transplant* 2014;49(7):865.
9. Devine SM, Vij R, Rettig M, et al. Rapid mobilization of functional donor hematopoietic cells without G-CSF using AMD3100, an antagonist of the CXCR4/SDF1 interaction. *Blood* 2008;112(4):990.
10. Schroeder MA, Rettig MP, Lopez S, et al. Mobilization of allogeneic peripheral blood stem cell donors with intravenous plerixafor mobilizes a unique graft. *Blood* 2017;129(19):2680.
11. Keeney M, Chin-Yee I, Weir K, et al. Single platform flow cytometric absolute CD34+ cell counts based on the ISHAGE guidelines. *Cytometry* 1998;34(2):61.
12. Sutherland DR, Nayar R, Acton E, et al. Comparison of two single platform ishage-based CD34 enumeration protocols on BD FACSCalibur and FACSCanto flowcytometers. *Cytotherapy* 2009;11(5):595.
13. Simon R. Optimal two-stage designs for phase II clinical trials. *Control Clin Trials* 1989;10(1).
14. Tukey JW. *Exploratory data analysis*. Reading, MA: Addison-Wesley.

15. Pantin J, Purev Tian X, et al. Effect of high dose plerixafor on CD34+ cell mobilization in healthy stem cell donors: results of a randomized crossover trial. *Haematologia* 2017;102(3):600.
16. Majeti R, Park CY, Weismann IL. Identification of a hierarchy of multipotent hematopoietic progenitors in human cord blood. *Cell Stem Cell* 2007;1(6):635.
17. Fruehauf S, Veldwijk MR, Seeger T, et al. A combination of granulocyte colony-stimulating factor (G-CSF) and AMD3100 (plerixafor) mobilizes more primitive peripheral blood progenitor cells than G-CSF alone: results of a European phase II study. *Cytotherapy* 2009;11(8):992.
18. Fruehauf S, Tricot G. Comparison of unmobilized and mobilized graft characteristics and the implications of cell subsets on autologous and allogeneic transplant outcomes. *Biol Blood Marrow Transplant* 2010;16(12):1629.
19. Das H, Imoto S, Murayama T, et al. Kinetic analysis of cytokine gene expression in patients with GVHD after lymphocyte infusion. *Bone marrow transplant* 2001;27(4):373.
20. Ju XP, Xu B, Xiao P, et al. Cytokine expression during acute graft-versus-host disease after allogeneic peripheral stem cell transplantation. *Bone marrow transplant* 2005;35(12):1179.
21. Lundqvist A, Smith AL, Takadashi Y, et al. Differences in the phenotype, cytokine gene expression and in vivo alloreactivity of T cells mobilized with plerixafor compared with G-CSF. *J Immunol* 2013;191:6241.
22. Rezvani K, Mielke S, Ahmadzadeh M, et al. High donor FOXP3-positive regulatory T cell (Treg) content is associated with a low risk of GVHD following HLA-matched allogeneic SCT. *Blood* 2006;108(4):1291.
23. Presland RB. Biology of chronic graft-vs-host disease: immune mechanisms and progress in biomarker discovery. *World J Transplant* 2016;6(4):608.
24. Higman MA, Vogelsang GB. Chronic graft versus host disease. *Br J Haematol* 2004;125(4):435.
25. Ratanatharathorn V, Ayash L, Lazarus HM, et al. Chronic graft-versus-host disease: clinical manifestation and therapy. *Bone Marrow Transplant* 2001;28(2):121.
26. Lee SJ, Vogelsang G, Flowers ME. Chronic graft-versus-host disease. *Biol Blood Marrow Transplant* 2003;9(4):215.
27. Storek J. Immunological reconstitution after hematopoietic cell transplantation-its relation to the contents of the graft. *Expert Opin Biol Ther* 2008;8(5):583.
28. Gattillo S, Markt S, Rizzo L, et al. Plerixafor on demand in ten healthy family donors as a rescue strategy to achieve an adequate graft for stem cell transplantation. *Transfusion* 2015;55(8):1993. 

SUPPORTING INFORMATION

Additional Supporting Information may be found in the online version of this article.

Appendix S1: Mobilization of peripheral blood stem cells with intravenous Plerixafor in allogeneic HLA-identical sibling donors.