

# Heavy menstrual bleeding on direct factor Xa inhibitors: Rationale and design of the MEDEA study

Eva N. Hamulyák MD<sup>1</sup>  | Hanke M. G. Wiegers MD<sup>1</sup> | Luuk J. J. Scheres MD, PhD<sup>1,2</sup>  |  
 Barbara A. Hutten PhD<sup>3</sup> | Maria E. de Lange MD<sup>4</sup> | Anne Timmermans MD, PhD<sup>4</sup> |  
 Peter E. Westerweel MD, PhD<sup>5</sup> | Marten R. Nijziel MD, PhD<sup>6</sup> |  
 Marieke J. H. A. Kruij MD, PhD<sup>7</sup> | Marije ten Wolde MD, PhD<sup>8</sup> | Paula F. Ypma MD, PhD<sup>9</sup> |  
 Frederikus A. Klok MD, PhD<sup>10</sup>   | Laurens Nieuwenhuizen MD, PhD<sup>11</sup> |  
 Sanne van Wissen MD, PhD<sup>12</sup>  | Marcel M. C. Hovens MD, PhD<sup>13</sup> |  
 Laura M. Faber MD, PhD<sup>14</sup> | Pieter W. Kamphuisen MD, PhD<sup>1,15</sup> |  
 Harry R. Büller MD, PhD<sup>1</sup> | Saskia Middeldorp MD, PhD<sup>1</sup>  

<sup>1</sup>Department of Vascular Medicine, Amsterdam UMC, Amsterdam Cardiovascular Sciences, University of Amsterdam, Amsterdam, The Netherlands

<sup>2</sup>Department of Internal Medicine, Radboud University Medical Center, Nijmegen, The Netherlands

<sup>3</sup>Department of Clinical Epidemiology, Biostatistics and Bioinformatics, Amsterdam UMC, Amsterdam Cardiovascular Sciences, University of Amsterdam, Amsterdam, The Netherlands

<sup>4</sup>Department of Gynecology and Obstetrics, Amsterdam UMC, University of Amsterdam, Amsterdam, The Netherlands

<sup>5</sup>Department of Internal Medicine, Albert Schweitzer Hospital, Dordrecht, The Netherlands

<sup>6</sup>Department of Hematology, Catharina Hospital Eindhoven, Eindhoven, The Netherlands

<sup>7</sup>Department of Hematology, Erasmus University Medical Centre, Rotterdam, The Netherlands

<sup>8</sup>Department of Internal Medicine, Flevo Hospital, Almere, The Netherlands

<sup>9</sup>Department of Hematology, Haga Hospital, The Hague, The Netherlands

## Abstract

**Background:** In premenopausal women, treatment with direct oral factor Xa inhibitors is associated with an increased risk of heavy menstrual bleeding (HMB) compared with vitamin K antagonists (VKA). Treatment with the direct oral thrombin inhibitor dabigatran appears to be associated with a reduced risk of HMB compared with VKA. These findings come from small observational studies or post hoc analyses of trials in which HMB was not a primary outcome. Use of tranexamic acid during the menstrual period may be effective in patients with HMB, but prospective data regarding efficacy and safety in patients on anticoagulant treatment are lacking.

**Rationale and Design:** A direct comparison of a factor Xa inhibitor and a thrombin inhibitor with HMB as primary outcome, as well as an evaluation of the effects of adding tranexamic acid in women with anticoagulant-associated HMB is highly relevant for clinical practice. The MEDEA study is a randomized, open-label, pragmatic clinical trial to evaluate management strategies in premenopausal women with HMB associated with factor Xa inhibitor therapy.

**Outcomes:** Women using factor Xa inhibitors with proven HMB, as assessed by a pictorial blood loss assessment chart (PBAC) score of >150, will be randomized to one of three study arms: (i) switch to dabigatran; (ii) continue factor Xa inhibitor with addition of tranexamic acid during the menstrual period; or (iii) continue factor Xa inhibitor without intervention. The primary outcome is the difference in PBAC score

The MEDEA study is registered at the Netherlands Trial registry: <https://www.trialregister.nl/trial/7760>

This is an open access article under the terms of the Creative Commons Attribution-NonCommercial-NoDerivs License, which permits use and distribution in any medium, provided the original work is properly cited, the use is non-commercial and no modifications or adaptations are made.

© 2020 Research and Practice in Thrombosis and Haemostasis published by Wiley Periodicals LLC on behalf of International Society on Thrombosis and Haemostasis (ISTH).

<sup>10</sup>Department of Thrombosis and Haemostasis, Leiden University Medical Centre, Leiden, The Netherlands

<sup>11</sup>Department of Internal Medicine, Máxima Medical Centre, Veldhoven, The Netherlands

<sup>12</sup>Department of Internal Medicine, OLVG, Amsterdam, The Netherlands

<sup>13</sup>Department of Internal Medicine, Rijnstate Hospital, Arnhem, The Netherlands

<sup>14</sup>Department of Internal Medicine, Red Cross Hospital, Beverwijk, The Netherlands

<sup>15</sup>Department of Internal Medicine, Tergooi Hospital, Hilversum, The Netherlands

#### Correspondence

Eva N. Hamulyák, Department of Vascular Medicine, Amsterdam UMC, Amsterdam Cardiovascular Sciences, University of Amsterdam, Meibergdreef 9, 1105AZ Amsterdam, The Netherlands.  
Email: e.n.hamulyak@amsterdamumc.nl

#### Funding information

The MEDEA study is sponsored by Amsterdam UMC – location AMC, Department of Vascular Medicine. An unrestricted investigator-initiated research grant by Boehringer Ingelheim BV is gratefully acknowledged. Boehringer Ingelheim BV was not involved in the study design or in the preparation of the current manuscript.

**Handling Editor:** Neil Zakai

before and after randomization. Here, we present the rationale and highlight several unique features in the design of the study.

#### KEYWORDS

dabigatran, factor Xa inhibitors, menorrhagia, prospective studies, tranexamic acid

## Essentials

- Management of anticoagulant-associated heavy menstrual bleeding (HMB) varies in clinical practice.
- The MEDEA study aims to evaluate management strategies of HMB while on factor Xa inhibitors.
- We present the rationale of this randomized, open-label, pragmatic clinical trial.
- We highlight some important and unique features in the study design.

## 1 | INTRODUCTION

Anticoagulant treatment is associated with an increased risk of bleeding, and abnormal uterine bleeding may occur in up to 70% of premenopausal women using anticoagulants in therapeutic doses.<sup>1</sup> Abnormal uterine bleeding includes disturbances of frequency, regularity, and duration of menstrual periods and can present as heavy menstrual bleeding (HMB) or intermenstrual bleeding. HMB is the most common clinical presentation, with estimates up to 35% in the general population, and is defined as >80 mL blood loss per menstrual cycle or as clinically excessive menstrual blood loss that disturbs the physical, emotional, social, or material quality of life.<sup>2</sup>

Direct oral anticoagulants (DOACs)—that is, the factor Xa inhibitors apixaban, edoxaban, and rivaroxaban, or the thrombin

inhibitor dabigatran etexilate—are currently the preferred anticoagulant compounds for the management of venous thromboembolism (VTE) and atrial fibrillation (AF).<sup>3,4</sup> The randomized controlled studies leading to their registration have shown a reduction in the incidence of major bleeding in DOAC-treated patients when compared to patients treated with vitamin K antagonists (VKAs).<sup>5,6</sup> In female VTE patients, however, treatment with factor Xa inhibitors has been associated with an increased risk of HMB when compared to VKA-treated women. Previous case series and small cohort studies reported an increased intensity and duration of menstrual bleeding in young women treated with factor Xa inhibitors.<sup>7-9</sup> These findings were confirmed in post hoc analyses of the large randomized trials of the respective factor Xa inhibitors. The EINSTEIN studies and the HOKUSAI-VTE study reported higher

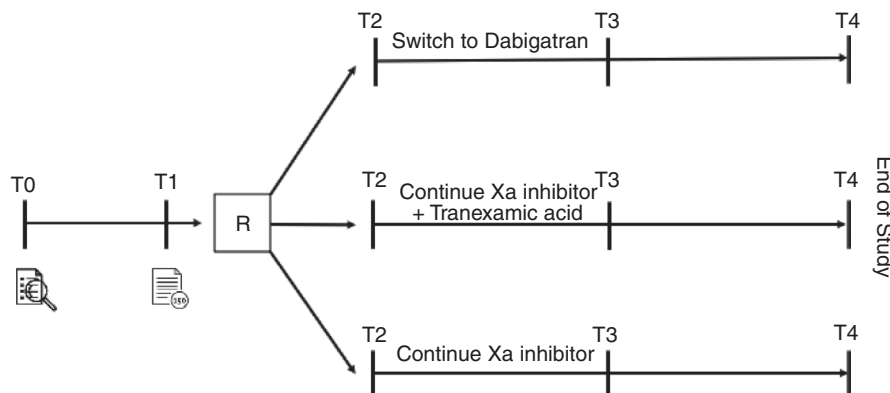

**FIGURE 1** Design of the MEDEA study

rates of abnormal uterine bleeding for respectively rivaroxaban (hazard ratio, 2.1; 95% confidence interval [CI], 1.6-2.9) and edoxaban (hazard ratio, 1.9; 95% CI, 1.1-2.5) in comparison with VKA-treated women.<sup>10,11</sup> In the AMPLIFY trial, the rate of abnormal uterine bleeding did not differ between apixaban and VKA (odds ratio [OR], 1.2; 95% CI, 0.7-2.0), but clinically relevant nonmajor bleeding was more likely of vaginal origin in apixaban-treated women.<sup>12</sup> Remarkably, a post hoc analysis of the VTE trials with dabigatran reported that treatment with dabigatran appears to be associated with a lower risk of abnormal uterine bleeding than VKA (OR, 0.6; 95% CI, 0.4-0.9).<sup>13</sup>

HMB is chronic in nature and can have a major impact on quality of life, particularly in women requiring long-term anticoagulant therapy.<sup>14,15</sup> Suggested management options for anticoagulation-associated HMB include modification of type and dose of anticoagulant therapy, addition of tranexamic acid during menstrual periods, or hormonal therapy.<sup>16</sup> Based on the post hoc analyses, it is important to investigate whether a switch from a factor Xa inhibitor to dabigatran may be beneficial in women with HMB. A direct comparison between factor Xa inhibitors and the thrombin inhibitor dabigatran, as well as the efficacy of adding tranexamic acid to reduce HMB, are needed to guide clinical decision making.

## 2 | STUDY OVERVIEW

### 2.1 | Design and study procedures

The MEDEA study is a multicenter, three-arm randomized, open-label clinical trial in women with HMB on factor Xa inhibitor treatment. A switch to dabigatran, addition of tranexamic acid to factor Xa inhibitor treatment during the menstrual period, and continuation of factor Xa inhibitor treatment without intervention will be evaluated, with each woman serving as her own control before and after randomization.

The study is largely incorporated in routine clinical care of patients with anticoagulant-associated HMB, aiming for a pragmatic clinical trial. Potentially eligible subjects have a screening visit for

a diagnostic workup and follow-up of HMB (T0). This workup includes an assessment of medical and gynecological history, including presence of HMB before initiation of anticoagulation, venous blood collection to evaluate presence of anemia, thrombocytopenia, liver or renal function impairment, and coagulopathy. Treatment of any other potential underlying disorder or concomitant disease, for instance, iron deficiency anemia, is at the discretion of the treating physician and not part of study procedures. Referral to a gynecologist for a detailed workup is optional and also at the discretion of the treating physician, since this is not standard practice in all hospitals. After informed consent, participants are followed for one menstrual cycle without intervention to prospectively document HMB using the pictorial blood loss assessment chart (PBAC), that is, the baseline PBAC score.<sup>17,18</sup> The PBAC is a simple clinical tool that has been validated as a semiobjective assessment of menstrual blood loss and pattern of menstrual cycle (Figure S1).<sup>17-20</sup>

After an eligibility check (T1), women can be enrolled and randomized in the study in a 1:1:1 ratio to one of the three study arms (Figure 1).

1. Switch from Xa inhibitor to dabigatran.
2. Continued treatment with Xa inhibitor continues as before, with addition of tranexamic acid 1000 mg three times a day on the first day of menstrual bleeding for 4 days.
3. Continued treatment with Xa inhibitor continues as before.

The randomization process is centralized through a web-based Good Clinical Practice approved tool, using random permuted blocks of varying size. The doses for the respective Xa inhibitors and dabigatran can be found in Table S1. The allocated study treatment will be continued for three menstrual cycles following randomization (T2, T3, T4). Laboratory assessments will be repeated at end of the study. During follow-up, participants are asked to complete the PBAC assessment, a general quality-of-life assessment, and the disease-specific menstrual bleeding questionnaire (MBQ)<sup>21</sup> (Table S2).

A noteworthy feature in the study's design is the escape option offered to women initially allocated to the continued factor Xa inhibitor treatment. At the initial randomization to this arm, this group

is immediately randomly allocated to either of the two intervention arms as a possible escape option. The Xa inhibitor treatment has to be continued at least one menstrual cycle after randomization, but if thereafter study participants require or wish to receive an intervention for HMB, this escape option can be offered. This allows for the crossover comparison, with each participant serving as her own control feature to maintain, albeit with more observations per participant.

Study participants are identified by the treating physician as women who present with the clinical problem of HMB. With currently 12 participating study sites in the Netherlands and more interested sites awaiting approval, we plan to recruit the required number of 120 women in approximately 2 years. This type of collaboration has proven to be extremely fruitful, exemplified by the success of the YEARS study (Netherlands Trial Registry number 5913) or the HighLow study (Netherlands Trial Registry number 3894). The study is embedded in the Dutch Thrombosis Network, and we aim for a close collaboration between the departments of Vascular Medicine and Gynecology and Obstetrics within the participating centers to recruit participants.

## 2.2 | Study population and eligibility

All premenopausal women, aged  $\geq 18$  years at randomization treated with a factor Xa inhibitor in any dose for any indication in whom HMB has occurred and who have one prospective PBAC score above 150 are potentially eligible for the current study. Participants must have an indication for anticoagulant treatment of  $>3$  months after study inclusion. We exclude women who started with hormonal therapy as a new intervention for HMB, women who are pregnant or currently planning for pregnancy, and women with cervical preneoplastic lesions or active malignancy. Eligibility criteria are listed in Table 1.

## 3 | RATIONALE FOR INCLUDING PATIENTS WITH ANY INDICATION FOR FACTOR XA THERAPY

Factor Xa inhibitor therapy is prescribed for various indications, most commonly VTE and AF. HMB associated with factor Xa

inhibitor therapy is observed in women with different indications for anticoagulant therapy, but the impact of HMB on quality of life presumably is similar. Therefore, any woman presenting with the clinical problem of HMB while on factor Xa inhibitor therapy, regardless of the indication, and who is expected to need long-term anticoagulation, is potentially eligible for participation in the MEDEA study. Women with a new indication for factor Xa inhibitor therapy may experience an aggravation of menstrual bleeding in the first cycle following treatment initiation. If discontinuation of anticoagulant treatment is expected shortly, an intervention for HMB may not be needed. In patients with an indication for long-term anticoagulation, continued presence of HMB can severely affect quality of life and requires appropriate management. As in the current study each woman serves as her own control, we defined an indication for anticoagulant treatment of at least 3 months after inclusion into the study as a strict inclusion criterion. Although we expect the majority of our study population to receive anticoagulant therapy for (recurrent) VTE, we plan exploratory analyses to evaluate outcomes in women with other indications and different treatment durations and recently started versus long-term anticoagulant therapy.

Different dose regimens of all three factor Xa inhibitors are allowed, as long as the clinical problem of HMB is present. The possibly diverse phenotype of bleeding with the respective factor Xa inhibitors and doses, as well as the large intraindividual variability of heavy menstrual bleeding, are accounted for as each woman serves as her own control.

## 3.1 | Study interventions

### 3.1.1 | Rationale for management strategies in a three-arm trial

*Switch from factor Xa inhibitor treatment to thrombin inhibitor dabigatran*

The safety and efficacy of dabigatran in treatment of VTE disease has been well established, and there is ample experience with this specific agent in clinical practice. As opposed to evidence from the post hoc analyses of the factor Xa inhibitor licensing trials, a

**TABLE 1** Eligibility criteria

Inclusion criteria	Exclusion criteria
<ul style="list-style-type: none"> <li>- Premenopausal women</li> <li>- Age <math>\geq 18</math> years</li> <li>- Anticoagulant treatment with a factor Xa inhibitor, either apixaban, edoxaban, or rivaroxaban</li> <li>- Indication for anticoagulant treatment <math>&gt; 3</math> months after inclusion</li> <li>- Heavy menstrual bleeding and a PBAC score <math>&gt; 150</math></li> <li>- Use of adequate contraceptive methods during study participation (this is advised to any woman on factor Xa inhibitors during fertile ages, regardless of study participation)</li> </ul>	<ul style="list-style-type: none"> <li>- Concomitant use of hormonal therapy as a new intervention for heavy menstrual bleeding</li> <li>- Pregnancy or currently planning for pregnancy</li> <li>- Active malignancy or current treatment with chemotherapy, immunotherapy, and/or radiotherapy</li> <li>- Cervical preneoplastic lesions</li> <li>- Contraindication for the registered products dabigatran or tranexamic acid</li> <li>- Any condition that, as judged by investigator, would place the subject at an increased risk of harm if she participated in the study</li> </ul>

Abbreviation: PBAC, pictorial blood loss assessment chart.

significantly lower risk of abnormal uterine bleeding in premenopausal women with VTE treated with dabigatran compared with warfarin (OR, 0.59; 95% CI, 0.39–0.90) was found in a recent post hoc analysis of the pooled RE-COVER-I, RE-COVER-II, and RE-MEDY trials.<sup>13</sup> Anticoagulant-associated HMB may be reduced while on thrombin inhibitor compared with VKA, but a thrombin inhibitor has not been compared directly to a factor Xa inhibitor in this context. Although dabigatran appears to be associated with higher rates of hematuria and gastrointestinal hemorrhage compared with factor Xa inhibitors, the incidence of abnormal uterine bleeding may be lower.<sup>22,23</sup> Observed differences among the different DOACs may be attributable to the post hoc nature of the evaluations and diversity in outcome assessment. However, there may be underlying mechanistic explanations for a differential effect of dabigatran in comparison with factor Xa inhibitors. Local thrombin generation in the endometrium of the uterus is of great importance in the cessation of menstrual bleeding, and it has been hypothesized that the capacity of standard dose dabigatran to inhibit thrombin may be locally exceeded by available thrombin. This allows for more local hemostatic action than warfarin, which continues to inhibit also higher thrombin levels, possibly explaining the observed rates in abnormal uterine bleeding between these two agents.<sup>24</sup> The MEDEA study is the first randomized clinical trial directly comparing dabigatran and a factor Xa inhibitor with HMB as the primary study outcome.

#### *Addition of tranexamic acid during menstrual period*

Tranexamic acid, an antifibrinolytic agent, is safe and effective in reducing blood loss during the menstrual period in the general female population and women with bleeding disorders, but does not influence duration of bleeding.<sup>25,26</sup> Tranexamic acid for this indication has never been evaluated in patients on anticoagulants. Current guidelines state active thromboembolic disease as a contraindication for treatment with tranexamic acid and recommend careful consideration before initiation of tranexamic acid in women with HMB and a history of VTE.<sup>27,28</sup> Adverse events related to the use of tranexamic acid, including thrombosis, have been identified from postmarketing experience by the Food and Drug Administration, and the characteristics of this population are unknown.<sup>29</sup> A recent meta-analysis including 22 randomized controlled trials with a total of 49 538 nonsurgical patients receiving tranexamic acid reported no increased risk of arterial or venous thrombosis.<sup>30</sup>

Tranexamic acid has been used in a variety of clinical and research settings, with good evidence of safety and efficacy during bleeding in populations at high risk of VTE, including high-quality large randomized controlled trials involving patients with major trauma or severe postpartum hemorrhage.<sup>31,32</sup> For women with a history of thrombosis, this is less certain, as they were excluded from the aforementioned trials. One previous nested case-control study of 134 VTE cases and 552 matched controls did not find a statistically significant association between tranexamic acid and VTE risk, reporting an adjusted OR for VTE of 3.20 (95% CI, 0.65–15.78).<sup>33</sup> With the available evidence of tranexamic acid use in other populations at high risk of VTE and considering that in the current study tranexamic acid is given in anticoagulated women, we do not expect an increased risk

for participants randomized adding tranexamic acid during the menstrual period. The MEDEA study will provide randomized evidence for the use of tranexamic acid as treatment of HMB in women with a history of thrombosis using factor Xa inhibitors.

#### *The course of HMB associated with factor Xa inhibitor treatment*

In the current study, one-third of the population continues the factor Xa inhibitor treatment without receiving an intervention for HMB. This control group serves to provide more insight in the course of HMB associated with factor Xa inhibitor treatment. In case the participants allocated to the no-intervention group require or wish to receive treatment for HMB during the study, the escape option in the study design provides an opportunity to cross over to dabigatran or the addition of tranexamic acid.

## 3.2 | Study outcomes

The primary outcome is the difference in PBAC score before (T1) and the mean PBAC score after randomization (T2, T3, T4), with each woman serving as her own control. Several secondary outcomes will be assessed. The disease-specific MBQ is a validated patient-reported outcome measure for HMB.<sup>21</sup> Quality of life will be assessed using this MBQ, in addition to a standardized 36-item short form survey. Duration of menses and occurrence of intermenstrual bleeding will be recorded in the electronic case report form, as well as a history of HMB before initiation of anticoagulation. An extensive evaluation of bleeding tendency is performed using the bleeding assessment tool of the International Society of Thrombosis and Hemostasis (ISTH) at inclusion.<sup>34</sup> In patients referred to a gynecologist for further evaluation, details of the gynecological workup are collected. Laboratory values, including hemoglobin and iron status, will be assessed at baseline (T1) and the end of the study (T4). Additionally, we will assess whether women who have had anticoagulant therapy for >6 months at the time of study inclusion experience different outcomes than women with a recent start of anticoagulant therapy, that is, <6 months.

During the study, any major, clinically relevant nonmajor and minor bleeding event other than HMB, as defined by the ISTH criteria, will be reported as well as any event requiring an adjustment in anticoagulant treatment, for example, a new-onset thromboembolic event while on anticoagulant treatment or interruption of anticoagulant treatment before minor or major surgical procedures. New symptomatic thromboembolic events (either venous or arterial) objectively confirmed by imaging will be recorded. All suspected clinical outcomes during the study period will be adjudicated by a committee blinded for treatment allocation. Adherence to the treatment regimens is assessed using a patient diary specific to the study.

## 4 | RATIONALE FOR USE OF THE PBAC SCORE AS A STUDY OUTCOME

All available methods to measure menstrual blood loss have limitations, but the PBAC is a simple clinical tool and has adequately

been validated as a semiobjective assessment of menstrual blood loss and pattern of menstrual cycle.<sup>17-20</sup> In a cohort study of 429 women who had previously participated in four prospective studies using PBAC as an outcome measure, the PBAC was found to have a low intraindividual variation.<sup>17</sup> In the MEDEA study, the primary outcome is the PBAC score three menstrual cycles after randomization, with each woman serving as her own control. This aspect of the study reduces the required number of participants considerably, without putting statistical and clinical validity at risk.<sup>35</sup>

#### 4.1 | Sample size considerations and statistical analysis

The study hypothesis is that either a switch from factor Xa inhibitor to dabigatran or addition of tranexamic acid during the menstrual period will decrease HMB, as objectively confirmed by a reduction in PBAC score. Each participant will serve as her own control. We assumed a PBAC score reduction of at least 25% to be clinically relevant. To ensure an 80% power ( $\beta = 0.2$ ) at a significance level of 0.05, approximately 34 women are needed to detect at least 25% reduction before and after intervention. Taking potential loss to follow-up into account, we settled on three groups of 40 women each.

The primary analysis will be the comparison in PBAC score before randomization (ie, while on factor Xa inhibitor [T1]) with the mean PBAC score after randomization (T2, T3, T4), reporting the paired differences before and after intervention with corresponding 95% CIs per treatment group. Differences between treatment groups at three cycles after randomization will additionally be explored. Efficacy analyses will be based on the intention-to-treat principle, including all patients who have received at least one dose of the allocated medication. Patients in the group that continues factor Xa inhibitor without intervention who opt for the escape option will be analyzed per protocol (ie, PBAC comparison before using the escape option) and in a modified intention-to-treat analysis (ie, PBAC comparison before and after using the escape option). An additional analysis will be performed, excluding all study subjects who received any intervention for HMB in addition to the intervention assigned in the trial.

Secondary analyses will comprise the association between PBAC scores, laboratory values, and outcomes of the quality-of-life questionnaires in each study group at baseline (T1) and end of study (T4) (Table S2). Exploratory analyses based on the type, dose, and indication of DOAC are planned.

### 5 | COMEDICATION: HORMONAL THERAPIES AND MEDICATION AFFECTING HEMOSTASIS

Combined oral contraceptives are effective in reducing HMB and are frequently used for treatment thereof. A post hoc analysis of the

EINSTEIN studies showed that hormonal therapy, estrogen-containing or progestin-only therapy, was not associated with an increased risk of recurrent VTE while on anticoagulant treatment with an adjusted hazard ratio of 0.56 (95% CI, 0.23-1.39).<sup>10</sup>

Levonorgestrel-containing intrauterine system (LNG-IUS) is also effective in reducing the amount and duration of menstrual blood loss and is safe in treatment of women receiving anticoagulants.<sup>36</sup> Initiation or switching of hormonal therapy, including combined oral contraception or an LNG-IUS, as a new intervention for HMB during study participation is not allowed. Newly started hormonal therapies would not allow estimation of the net effects of the studies' therapies and invalidate analyses and subsequent results.

Continuation of hormonal therapy while on anticoagulant treatment is a reasonable option, as it is an adequate contraceptive method and sudden cessation may aggravate HMB even further. Nonsteroidal inflammatory drugs are commonly used to reduce menstrual blood loss and pain and affect hemostasis. The use of any medication that affects hemostasis, including antiplatelet therapy, is discouraged given the risk of increased bleeding while also on therapeutically dosed anticoagulant therapy; chronic use, however, is allowed and carefully recorded.

### 6 | EXPECTED RESULTS AND FUTURE STEPS

The MEDEA study may change clinical practice in women with anticoagulation-associated HMB and aid the treating physician and the patient in choosing an optimal, evidence-based treatment strategy. This will be the first clinical trial involving a direct comparison of the thrombin inhibitor dabigatran and the respective factor Xa inhibitors. The practically applicable PBAC score will be used as an identifier of HMB and study end point. The trial interventions, crossover design and simple clinical tool to objectify HMB allow for a smooth implementation of the study in routine clinical care. If the trial results indicate dabigatran indeed to be associated with less HMB, this may support the use of dabigatran as preferred treatment option in women of reproductive age. Additionally, this trial will provide prospective data on the effects of tranexamic acid in women with an indication for anticoagulation. Although this strategy in treatment of HMB is applied in clinical practice by some, others are reluctant due to lack of evidence in the population of women with an indication for therapeutically dosed anticoagulation.

Possible next steps include lowering the age at study inclusion from 18 years to 12 years, thus allowing adolescents presenting with HMB while on factor Xa inhibitor treatment to participate in the trial as well. Both dabigatran and rivaroxaban were very recently evaluated in the pediatric population in the DIVERSITY and EINSTEIN-Jr studies, with good efficacy and safety profiles in comparison with standard anticoagulation.<sup>37,38</sup> Furthermore, the net benefit of dose reduction in women with HMB while on factor Xa inhibitor treatment requires additional investigation, possibly in an extension of the current trial.



In conclusion, the MEDEA study is a pragmatic clinical trial with the aim to optimize treatment of anticoagulation-associated HMB. Outcomes and experience attained from this study could provide groundwork for guidelines on anticoagulant treatment in women of reproductive age.

## RELATIONSHIP DISCLOSURE

ENH, HMW, BAH, MEL, AT, PEW, MRN, MW, PFY, LN, SW, LMF, MMH, PWK, HRB have no conflicts of interest to declare. LJS was a PhD candidate of the CREW project (2013T083) funded by the Netherlands Heart Foundation from 2014 to 2018 and has received funding for the printing of his doctoral thesis from the Dutch Heart Foundation, Dutch Federation of Coagulation Clinics, Stichting tot Steun Promovendi Vasculaire Geneeskunde, Bayer, Daiichi Sankyo, LEO Pharma, and Pfizer. SM reports grants and personal fees from Bayer, BMS Pfizer, Boehringer Ingelheim, Daiichi Sankyo and Portola, during the conduct of the study; grants and personal fees from GSK and Aspen; and personal fees from Sanofi, outside the submitted work. FAK reports research grants from Bayer, Bristol-Myers Squibb, Boehringer Ingelheim, Daiichi-Sankyo, MSD, Actelion, the Dutch Heart Foundation, and the Dutch Thrombosis Association. MJK reports fees from Bayer and grants from the Dutch Thrombosis Foundation, Innovation Fund, the Netherlands Organization for Health Research and Development (ZonMW), Bayer, Daiichi-Sankyo, Boehringer Ingelheim, Pfizer, and Obi, all paid to her institution.

## AUTHOR CONTRIBUTIONS

ENH, LJS, HRB, and SM are responsible for the concept and design of the study. All authors contributed to the design and the conduct of the study. ENH, HMW, LJS, BAH, and SM wrote the first draft of the manuscript. All authors revised the manuscript critically and approved the final version of the manuscript.

## ORCID

Eva N. Hamulyák  <https://orcid.org/0000-0002-9340-8771>  
 Frederikus A. Klok  <https://orcid.org/0000-0001-9961-0754>  
 Saskia Middeldorp  <https://orcid.org/0000-0002-1006-6420>

## TWITTER

Luuk J. J. Scheres  @ScheresLuuk  
 Frederikus A. Klok  @Erik\_Klok\_MD  
 Sanne Wissen  @svanwissen  
 Saskia Middeldorp  @middeldorps

## REFERENCES

- Klok FA, Schreiber K, Stach K, et al. Oral contraception and menstrual bleeding during treatment of venous thromboembolism: expert opinion versus current practice: combined results of a systematic review, expert panel opinion and an international survey. *Thromb Res*. 2017;153:101–107.
- Munro MG, Critchley HO, Broder MS, Fraser IS, FIGO Working Group on Menstrual Disorders. FIGO classification system (PALM-COEIN) for causes of abnormal uterine bleeding in nongravid women of reproductive age. *Int J Gynaecol Obstet*. 2011;113(1):3–13.
- Kearon C, Akl EA, Ornelas J, et al. Antithrombotic therapy for VTE disease: CHEST guideline and expert panel report [published correction appears in *Chest*. 2016 Oct; 150(4):988]. *Chest*. 2016;149(2):315–352.
- Konstantinides SV, Meyer G, Becattini C, et al. 2019 ESC Guidelines for the diagnosis and management of acute pulmonary embolism developed in collaboration with the European Respiratory Society (ERS). *Eur Heart J*. 2020;41(4):543–603.
- van Es N, Coppens M, Schulman S, Middeldorp S, Büller HR. Direct oral anticoagulants compared with vitamin K antagonists for acute venous thromboembolism: evidence from phase 3 trials. *Blood*. 2014;124(12):1968–1975.
- van der Hulle T, Kooiman J, den Exter PL, Dekkers OM, Klok FA, Huisman MV. Effectiveness and safety of novel oral anticoagulants as compared with vitamin K antagonists in the treatment of acute symptomatic venous thromboembolism: a systematic review and meta-analysis. *J Thromb Haemost*. 2014;12(3):320–328.
- Ferreira M, Barsam S, Patel JP, et al. Heavy menstrual bleeding on rivaroxaban. *Br J Haematol*. 2016;173(2):314–315.
- Beyer-Westendorf J, Michalski F, Tittl L, Hauswald-Dörschel S, Marten S. Vaginal bleeding and heavy menstrual bleeding during direct oral anti-Xa inhibitor therapy. *Thromb Haemost*. 2016;115(6):1234–1236.
- Myers B, Webster A. Heavy menstrual bleeding on rivaroxaban - comparison with apixaban. *Br J Haematol*. 2017;176(5):833–835.
- Martinelli I, Lensing AW, Middeldorp S, et al. Recurrent venous thromboembolism and abnormal uterine bleeding with anticoagulant and hormone therapy use. *Blood*. 2016;127(11):1417–1425.
- Scheres L, Brekelmans M, Ageno W, et al. Abnormal vaginal bleeding in women of reproductive age treated with edoxaban or warfarin for venous thromboembolism: a post hoc analysis of the Hokusai-VTE study. *BJOG*. 2018;125(12):1581–1589.
- Brekelmans MP, Scheres LJ, Bleker SM, et al. Abnormal vaginal bleeding in women with venous thromboembolism treated with apixaban or warfarin. *Thromb Haemost*. 2017;117(4):809–815.
- Huisman MV, Ferreira M, Feuring M, Fraessdorf M, Klok FA. Less abnormal uterine bleeding with dabigatran than warfarin in women treated for acute venous thromboembolism. *J Thromb Haemost*. 2018;16(9):1775–1778.
- Govorov I, Ekelund L, Chairati R, et al. Heavy menstrual bleeding and health-associated quality of life in women with von Willebrand's disease. *Exp Ther Med*. 2016;11(5):1923–1929.
- Huq FY, Tvarokova K, Arafa A, Kadir RA. Menstrual problems and contraception in women of reproductive age receiving oral anticoagulation. *Contraception*. 2011;84(2):128–132.
- Boonyawat K, O'Brien SH, Bates SM. How I treat heavy menstrual bleeding associated with anticoagulants. *Blood*. 2017;130(24):2603–2609.
- Hald K, Lieng M. Assessment of periodic blood loss: interindividual and intraindividual variations of pictorial blood loss assessment chart registrations. *J Minim Invasive Gynecol*. 2014;21(4):662–668.
- Higham JM, O'Brien PM, Shaw RW. Assessment of menstrual blood loss using a pictorial chart. *Br J Obstet Gynaecol*. 1990;97(8):734–739.
- Magnay JL, O'Brien S, Gerlinger C, Seitz C. A systematic review of methods to measure menstrual blood loss. *BMC Womens Health*. 2018;18(1):142.
- Herman MC, Mak N, Geomini PM, et al. Is the Pictorial Blood Loss Assessment Chart (PBAC) score associated with treatment outcome after endometrial ablation for heavy menstrual bleeding? A cohort study. *BJOG*. 2017;124(2):277–282.
- Matteson KA, Scott DM, Raker CA, Clark MA. The menstrual bleeding questionnaire: development and validation of a comprehensive

- patient-reported outcome instrument for heavy menstrual bleeding. *BJOG*. 2015;122(5):681–689.
22. Bhatt NR, Davis NF, Nolan WJ, et al. Incidence of visible hematuria among antithrombotic agents: a systematic review of over 175,000 patients. *Urology*. 2018;114:27–32.
  23. Miller CS, Dorreen A, Martel M, Huynh T, Barkun AN. Risk of gastrointestinal bleeding in patients taking non-vitamin K antagonist oral anticoagulants: a systematic review and meta-analysis. *Clin Gastroenterol Hepatol*. 2017;15(11):1674–1683.e3.
  24. Dale B, Eikelboom JW, Weitz JI, et al. Dabigatran attenuates thrombin generation to a lesser extent than warfarin: could this explain their differential effects on intracranial hemorrhage and myocardial infarction? *J Thromb Thrombolysis*. 2013;35(2):295–301.
  25. Bryant-Smith AC, Lethaby A, Farquhar C, Hickey M. Antifibrinolytics for heavy menstrual bleeding. *Cochrane Database Syst Rev*. 2018;4(4):CD000249.
  26. Leminen H, Hurskainen R. Tranexamic acid for the treatment of heavy menstrual bleeding: efficacy and safety. *Int J Womens Health*. 2012;4:413–421.
  27. National Institute for Health and Clinical Excellence. Heavy Menstrual Bleeding. NICE Guidelines. London, UK: National Institute for Health and Clinical Excellence; update March 2018.
  28. European Medicines Agency. EMA/CPMP/902/00 – Cyklo-f, April 2020. [https://www.ema.europa.eu/en/documents/referral/opinion-on-following-article-10-referral-cyklo-f-international-non-proprietary-name-inn-tranexamicacid\\_en.pdf](https://www.ema.europa.eu/en/documents/referral/opinion-on-following-article-10-referral-cyklo-f-international-non-proprietary-name-inn-tranexamicacid_en.pdf). Accessed July 24, 2020.
  29. The US Food and Drug Administration. Highlights of Prescribing Information. LYSTEDA (Tranexamic Acid) Tablets for Oral Use; 2013. [https://www.accessdata.fda.gov/drugsatfda\\_docs/label/2013/022430s004lbl.pdf](https://www.accessdata.fda.gov/drugsatfda_docs/label/2013/022430s004lbl.pdf)2015. Accessed July 24, 2020.
  30. Chornenki NLJ, Um KJ, Mendoza PA, et al. Risk of venous and arterial thrombosis in non-surgical patients receiving systemic tranexamic acid: a systematic review and meta-analysis. *Thromb Res*. 2019;179:81–86.
  31. CRASH-2 trial collaborators, Shakur H, Roberts I, et al. Effects of tranexamic acid on death, vascular occlusive events, and blood transfusion in trauma patients with significant haemorrhage (CRASH-2): a randomised, placebo-controlled trial. *Lancet*. 2010;376(9734):23–32.
  32. WOMAN Trial Collaborators. Effect of early tranexamic acid administration on mortality, hysterectomy, and other morbidities in women with post-partum haemorrhage (WOMAN): an international, randomised, double-blind, placebo-controlled trial. *Lancet*. 2017;389(10084):2105–2016.
  33. Sundström A, Seaman H, Kieler H, Alfredsson L. The risk of venous thromboembolism associated with the use of tranexamic acid and other drugs used to treat menorrhagia: a case-control study using the General Practice Research Database. *BJOG*. 2009;116(1):91–97.
  34. Rodeghiero F, Tosetto A, Abshire T, et al. ISTH/SSC bleeding assessment tool: a standardized questionnaire and a proposal for a new bleeding score for inherited bleeding disorders. *J Thromb Haemost*. 2010;8(9):2063–2065.
  35. Louis TA, Lavori PW, Bailar JC 3rd, Polansky M. Crossover and self-controlled designs in clinical research. *N Engl J Med*. 1984;310(1):24–31.
  36. Lethaby A, Hussain M, Rishworth JR, Rees MC. Progesterone or progestogen-releasing intrauterine systems for heavy menstrual bleeding. *Cochrane Database Syst Rev*. 2015;4:CD002126.
  37. Brandão LR, Albisetti M, Halton J, et al. Safety of dabigatran etexilate for the secondary prevention of venous thromboembolism in children. *Blood*. 2020;135(7):491–504.
  38. Male C, Lensing AWA, Palumbo JS, et al. Rivaroxaban compared with standard anticoagulants for the treatment of acute venous thromboembolism in children: a randomised, controlled, phase 3 trial. *Lancet Haematol*. 2020;7(1):e18–e27.

#### SUPPORTING INFORMATION

Additional supporting information may be found online in the Supporting Information section.

**How to cite this article:** Hamulyák EN, Wieggers HMG, Scheres LJJ, et al. Heavy menstrual bleeding on direct factor Xa inhibitors: Rationale and design of the MEDEA study. *Res Pract Thromb Haemost*. 2021;5:223–230. <https://doi.org/10.1002/rth2.12471>